

THE UNIVERSITY OF MEMPHIS®

Standard Design Requirements

Updated May 2024 TP

DETAILED UNIVERSITY DESIGN REQUIREMENTS

Space Requirements

Custodial

Landscaping and Site Design

Site Planning

Landscape Planting

Planting Character

Composition and scale of plant material at maturity

Planting and Campus Security

Irrigation

Plant Species and Diversity

Street Tree Planting

Planting Sizes

Tree Protection during Construction

Sod installation and Repair Requirements

Landscape Accessories

Site Accessories

Bike Racks

Bus Shelters

Fences and Gates

Recreational Facility and Playground Equipment

Signage

Site, Street and Mall Furnishings

Site Walls / Seat Walls / Retaining Walls

Walk, Road, and Parking

Traffic Control Bollards

Campus Driveway Applications

Decorative Bollards

Concrete Sidewalk / Pavement detail

Pedestrian Walkway Pavement Pattern design

Inlets

Parking Design Requirements

Asphalt detail

Heavy Duty Asphalt detail

Crosswalks

Curbing: Street, Medians and Parking Lots

Curb Ramps

Walk Pavements and Handicap Access Ramps

Standard Ramp

Special Pavements

Storm Water

Carpentry and Painting

Ceilings

Doors

Security Glazing

Stairs

Handrails and Railings

Interior Painting

Exterior Painting

Roofing

Lock shop

Heating, Ventilation, and Air Conditioning (HVAC)

Environmental Conditions and General Design Requirements

Domestic Water

Equipment

Roof Top Units

Mechanical Insulation

HVAC Controls, Building Automation and Instrumentation

Actuators and Operators

Sensors and Transmitters

Control Valves

Control Dampers

Energy Management System

Electric and Electronic Control System for HVAC

Pneumatic Control System

Pneumatic and Electric Control System

Sequence of Operation for HVAC Controls

HVAC Piping and Pumps

Hydronic Piping

Above Ground Hydronic Piping

In-Line Centrifugal Hydronic Pumps

Base-Mounted Centrifugal Hydronic Pumps

Vertical-Mounted, Double Suction Centrifugal Hydronic Pumps

Automatic Condensate Pump Units

Steam and Condensate Piping and Pumps

Steam and Condensate Heating Piping

Underground Steam and Condensate Heating Piping

Electric Driven Steam Condensate Pumps

Refrigerant Safety Relief Valve Discharge Piping

Refrigerants

HVAC Water Treatment

HVAC Air Distribution

HVAC Ducts and Casings

Non-metal Ducts

HVAC Casings

Dampers

Access Doors

Flexible Connectors

Flexible Ducts

Duct Liners

HVAC Fans

Centrifugal HVAC Fans

HVAC Power Ventilators

Bath Exhaust

Variable – Air – Volume Units

Air Outlets and Inlets

Return Air Grilles

Supply Diffusers

Fabric Air Distribution Devices

HVAC Gravity Up blast Ventilators

HVAC Air Cleaning Devices

Central Heating Equipment

Heat Exchangers for HVAC

Central Cooling Equipment

Central HVAC Equipment

Indoor Central Station Air Handler – Example TRANE # MCCA008

Packaged Outdoor HVAC Equipment

Packaged, Outdoor, Central-Station Air-Handling Units

Decentralized HVAC Equipment

Room Air Conditioners

Computer Room Air Conditioners

Split - System Air Conditioners

Air - Source Unitary Heat Pumps

Humidity Control Equipment

Outdoor Airflow Control

Cooling Towers

VFD on AHUs, Fans, and Pumps

Operation and Maintenance of Facility Fuel Systems

Operation and Maintenance of HVAC Piping and Pumps

Operation and Maintenance of HVAC Air Distribution

HVAC Air Duct Cleaning

Operation and Maintenance of Central Cooling Equipment

Common Motor Requirements for HVAC Equipment

Expansion Fittings and Loops for HVAC Piping

Meters and Gages for HVAC Piping

General - Duty Valves for HVAC Piping

Specialty Valves by Need

Hangers and Supports for HVAC Piping and Equipment

Heat Tracing for HVAC Piping

Identification for HVAC Piping and Equipment

Anti-Microbial Coatings for HVAC Ducts and Equipment

Anti-Microbial Ultraviolet Emitters for HVAC Ducts and Equipment

Testing, Adjusting, and Balancing for HVAC

HVAC Insulation

Duct Insulation

Equipment Insulation

Piping Insulation

Commissioning of HVAC

Plumbing

General Design Requirements

Catch basins

Fire Protection

Water Entrance

Manholes

Plumbing Fixtures

Faucets

Pipes and Pipe Fittings

Valves

Reduced Pressure Devices

ELECTRICAL

General Design Requirements

Basic Materials and Methods

Special Systems

Controls

High Voltage Distribution

Service and Distribution

Raceways, Conduits and Trenches

Circuit Breakers

Electric Conduit Fittings

Electric Panels

Electric Wire and Cables

Elevators

Emergency Keyed Lock Box for Elevators

Emergency Phones

Exterior Lighting

Exterior Building Lighting

Exterior Light Levels

Street and Parking Lot Lighting

Post-top Style Street and Parking

Post Top Fixture

Generators

High Voltage Switches

Interior Lighting

Transformers

ELECTRONIC

Fire Alarm Systems and Components

INTERIOR DESIGN

General Requirements

Restrooms

Toilet, Bath, and Laundry Accessories

Mirrors

Grab Bars

Soap Dispensers

Tissue Dispensers

Sanitary Napkin Disposal

Signage

Architectural Woodwork

Room Numbering Procedure

Interior tile

Resilient Base

Resilient Stair Treads and Risers

Resilient Accessories

Chalkboards

LCS Board

Plastic Toilet Compartments

Exterior Design

Signage

Windows

Additional Guidelines

DETAILED UNIVERSITY DESIGN REQUIREMENTS

Space Requirements

- -Design internal spaces to permit flexibility. Consider floor heights, loading, atmospherics, lighting, accessibility, security, economical building module, HVAC, etc.
- -All new or renovated mechanical equipment rooms shall be of adequate size to ensure proper headroom and provide for removal of all equipment components without encountering any architectural or equipment barriers.
- All mechanical rooms to have an adjacent maintenance storage room of not less than 50 square feet.
- Each new or renovated custodial closet shall be a minimum of 50 square feet. Include a minimum of one closet per 15,000 square feet of gross building space and a minimum of one closet per floor. Locate closets near restrooms. The rooms shall not be entrances to mechanical rooms, roof hatches, or other spaces.
- Provide a main custodial closet near an accessible entrance, delivery area, or elevator of a minimum of 100 square feet. Design space for the storage of all equipment and a thirty (30) day supply of cleaning supplies.
- Provide each building with a custodial personnel break area.
- Install or relocate telephone switchgear in a separate telephone equipment room not in custodial closets or mechanical equipment rooms. Telecommunication closets are required in each quadrant of the facility (See Telecommunications section for details.)
- Provide a hallway / alcove space 48" deep by 40" wide for each vending machine.
- Provide each building with a recycling room near a delivery area easily accessible from the interior and exterior of the building.

Custodial

- Custodial closets to have four shelves, a floor service sink and 120-volt electrical outlet (20 amp) capable of charging battery powered floor machines.
- All closet doors to swing out or not interfere with required clearances/floor areas.
- The custodial break area (1 per building) to have HVAC, lighting, electrical outlets, a sink with hot and cold water, and a shelf.

Landscaping and Site Design

- Final landscape design to be approved by the University. Include all landscaping and irrigation systems in base Construction Contract.
- Specific, desirable plant materials for the campus are:

- Large Trees - Willow Oak, Water Oak, Pin Oak, or Red Maple.
- Large Accent Trees - Kentucky coffee tree, Yellowwood, Eastern Red Cedar, or Ginkgo.
- Small or Flowering Trees - Zelchova, Fringe Tree, Goldenrain Tree, Red Bud, Dogwood, Yoshino, or Crape myrtle.
- Large Shrubs - American Holly, Foster Holly, or Yaupon.
- Medium Shrubs - Needlepoint Holly, Pfitzer Juniper, Carissa Holly, Seagreen Juniper, Aucuba, or Azalea.
- Small Shrubs - Dwarf Yaupon, Barberry, Burning Bush, or Nandina.
- Ground Covers - Variegated Lirope, Big Blue Lirope, Pachysandra, or English Ivy.

Site Planning

- Careful site design the arrangement of facilities and landscape elements on the land is fundamental to the character of place. Site design entails identifying and strengthening desired relationships among built elements and creating a satisfying relationship of building to open spaces. Attention to important factors such as setbacks, creation of campus space, and preservation and enhancements of views and wayfinding elements will ensure site developments that respect and enhance both campus and neighborhood while meeting University needs.
- Wherever possible, building setbacks should match nearby existing buildings. Where there is a significant variation between setbacks from walkways, public building, sidewalks, or street curb, new buildings should match the lesser setback to frame the walkway or public space effectively.
- Create a Sense of Place: While a variety of plantings, paving, public art, and other landscape design elements should provide a unique identity to each of the campus' major public spaces it is critical to emphasize key elements of continuity that convey a cohesive quality to the campus:
 - Continuous walkways that utilize consistent paving;
 - Wherever possible, tree lining important walkways;
 - Continuity in signage, lighting, and benches as well as other site furnishings.

Landscape Planting

- Space definition: Spatial organization of the campus landscape is determined by 3 major components: buildings, topography, and woody plants (trees and shrubs). Roads and walkway are also important, but their role is subordinate to the three-dimensional strength of building, land, trees and shrubs. Trees and shrubs are key elements that define spatial order and significantly affect the quality of the campus environment. Trees and shrubs should be used purposefully to achieve desired functions and spatial effects such as limiting or directing views, creating microclimates and intimate overhead enclosures, framing spaces for compositional closure, and define and reinforce major campus spaces and wayfinding pathways.

Planting character

- The most dominant and mature landscape at the University is the Dunavant Plaza, Emeriti Grove and Sculpture Garden area. This includes designed landscapes and natural tree groupings. It is recommended that the informal naturalistic style of a variety of plant species and sizes, arranged in non-geometric, naturalistic patterns around irregular spaces be the preferred approach for campus plantings. This does not negate the positive impact of the geometric design of the Student Plaza and Alumni Mall. Site design should be dictated by specific elements and conditions. Contained courtyards and garden areas that do not freely connect with the larger campus landscape may adopt alternative planting approaches, such as geometric layout or monocultures.
- A great advantage of the naturalistic approach is that perfection can be achieved in many ways over time, and the overall design is resilient to tree losses that eventually come with storms and disease. Trees can be lost and replanted without upsetting the overall integrity of the composition.
- The species of plants selected for use on the campus should possess visual traits that are representative of or similar to the plants indigenous to the mid-southern United States, and are appropriately long-lived and refined to reflect the enduring quality of the campus. Plants that are highly exotic in their visual aspect should not be used in prominent locations, even if they be of horticultural interest. There is great intrinsic beauty in the native flora; it should be the guiding purpose of the planting design to capitalize on it. Campus planting design should be simple and seek to promote a mood of tranquility similar to that found in nature. The design should be kept free of distracting elements.

Composition and scale of plant material at maturity

- The chief compositional goals of the campus plantings are to achieve proper scale and unity within and among campus areas. The size of shrubs, their mature growth, and plant beds should be considered with respect to scale and compositional relationship to adjacent buildings, roads, sidewalks, plazas and spaces. Generally, plantings should be simple and appropriately scaled to the campus. Intricate, domestic scaled plantings are inappropriate when arbitrarily located next to institutional size buildings or floating in large lawns and open spaces of the campus.
- Small garden scale plantings and flower beds are important; however they should relate to the campus through proper hierarchies and located in areas designed for intimate gatherings or specific walk nodes. Gardens and flower beds must be designed as part of a larger design of steps, walls, walks, paved terraces and topography that is arranged and seized to relate to adjacent buildings and surrounding landscapes.

- Unity is a particularly important function of campus plantings because of the significant variety that exists among campus architectural designs. A prevailing visual-sensory unity or sense of place of extended duration that is felt across large areas speaks to a different aesthetic experience than a campus landscape of competing visual compositions designed as separate projects, sharing only coincidental adjacencies. Landscape unity in a naturalistic style, over broad areas, produces an appropriate expression for a public institution of higher education, research, and public outreach.

Planting and Campus Security

- Safety on campus, building arrangement and landscape design employs the principles of “Crime Prevention Through Environmental Design” (CPTED) *Timothy D. Crowe, 2000*. The CPTED concept assumes that proper design and effective use of the built environment can lead to a reduction in the fear and incidence of crime, and to improvements in the quality of life in the campus setting.
- A key factor in a feeling of security is visual openness, particularly at night. Areas of dense shrubbery can be perceived as dark and unsafe at night. Campus security is the result of many factors (activity level, policing, informal and organized surveillance, light levels, hour of day, etc.), hence vegetation should be selected (based on mature growth characteristics), organized, and maintained to promote openness and good visibility. The goal is to maintain high levels of visibility in the most frequented areas of campus without dispensing with the attractive, space-defining qualities that plants bring to the environment OR working against the natural growth characteristics (size, shape, and branching) of trees and shrubs. Plant selection and use should be with the key to minimize “pruning” for enhancing campus security.
- Basic guiding principles of landscape design based on CPTED guidelines:
- Planting and selection of landscape materials should leave sightlines open and clear of obstacles that offer places of concealment.
- Select shrubs whose mature height characteristics is approximately 3’. Shrubs requiring pruning should be trimmed to 3’, or at least below windowsills.
- Lower tree branches trees should - through natural growth or pruning - be a minimum of 6’ to 8’ off the ground.
- If graffiti is a known problem in an area, use thorny plants as a natural barrier to deter unwanted entry. Specify vines or planted wall coverings to deter graffiti. Avoid blank spaces, which may invite graffiti.
- Provide landscaping and fencing that does not create hiding places.
- Provide attractive durable fencing whenever possible. Consider creative solutions to fencing schemes that work aesthetically and functionally.
- Use lighting in the landscaping, both for security and aesthetics.

Irrigation

- Design to appropriately irrigate all lawn areas, plant beds, and landscape islands on separate zones.
- Irrigation system shall be either RAINBIRD, HUNTER, or approved equal. The proposed system shall be 100% compatible with a RAINBIRD system. RAINBIRD IRRIGATION SYSTEM comprises most of the irrigation systems on campus. The system shall be of commercial grade materials and equipment.
- In-ground valve box, above ground valve box, and landscape irrigation components - As approved.

Plant Species and Diversity

- Existing campus plant material varies widely. A broad base of material is good. General guidelines for the placement of plant material around new and existing buildings will create a consistent campus image. Some broad guidelines for plant material choices are:
 - To the extent possible, tree and shrub plantings should consist of species native to the mid-southern region of the United States. The USDA Hardiness Zone shows Memphis in a Hardiness Zones of 6a to 8a. Use native plants that are hardy in Zone 7. In most cases this enhances the long term adaptation of plants to the campus and creates a visual setting harmonizing with the beauty of the region.
 - Use of poisonous and invasive plant material is prohibited.
 - The planting strategy is to employ long-lived non-invasive trees and shrubs adapted to the specific exposures, moisture conditions, climate and soils of the campus. Indigenous plants will help create a distinctive, regionally appropriate campus environment. Plan for mature size of plants.
 - Planting should be diverse in species and age of plants to maintain resilience in the event of environment changes such as disease or severe climatic stress that targets specific plants. Visual unity should also be fostered. Achieve variety in unity by planting groups of similar species or different species with similar forms and colors.
 - Avoid area plantings with a wide variety of singular specimens with varied forms and colors.
 - All plant selection for specific projects shall be reviewed and approved by the Campus Landscape Architect.

Street Tree Planting

- Street trees are proposed in both tree lawns and in a paved condition.
- When trees are proposed in a lawn area where site grades, soils, and subsurface utilities allow, tree lawns may be depressed below the level of adjacent paved areas or lawn to create simple bio retention areas. Choose trees that can accommodate intermittent inundation.

- Proposed street trees in paved areas (sidewalks) shall be planted in appropriate tree pits with an approved tree grate. The standard is NEENAH FOUNDRY “*Metropolitan Collection Tree Grate R-8707*” <http://www.nfco.com/municipal/products/tree-grates/metropolitan/>

Planting Sizes

- For general landscape tree plantings, the installation size may typically vary from a minimum of 2-2 1/2” to 6” caliper depending upon the location, project budget, and species of tree. Size and number will also depend on adjacent use, new facilities, etc.
- Preferred tree sizes are a minimum of 2 – 2 1/2” to 4 1/2” caliper. This size gives added assurance that the tree will have reasonable visual effect at planting, be large enough to overcome the vulnerability to damage of smaller trees, and be small enough not to require extensive excavation and shipping cost of larger caliper sizes.

Tree Protection during Construction

- Prior to any site disturbance with new construction or facility repair activities, tree preservations shall be placed around all trees to remain. A 5’ tall chain link fence with 6’ metal posts set at 8’ centers shall be installed at the drip line of the trees or as directed by the Campus Landscape Architect.
- Stockpiling of materials within this preservation zone is strictly prohibited. Materials shall include but not limited to; top soil, construction equipment, parking of vehicles, or storage of supplies. Also the burning of materials, re-grading causing runoff or flooding, spilling of toxic materials, or spraying of herbicides.
- Trees shall be maintained throughout construction to promote and maintain healthy growth. They shall be watered and fertilized whenever soil moisture is below 50% of field capacity. Root areas of the tree where soil has been compacted due to construction shall be vertically aerated at the direction of a certified Arborist.

Sod Installation and Repair Requirements

- Where new construction or facility repairs activities has taken place in lawn areas, said areas are to be regarded, soil vertically mulched (aerated), and soil amenities added for sod growth.
- These actions shall include but not limited to the following:
- Remove all construction debris, sticks, and rocks / gravel from the area.
- The soil shall be thoroughly tilled to a depth of 6” with required soil amenities. Sod area shall be fine graded to remove all ridges and depressions and the surface cleared of all stone and debris.
- Sod shall be a minimum of 3/4” thick, free of weeds and pests and cut no more than 24 hours prior to planting.

- All disturbed areas are to be sodded with Palisade Zoysia Sod or approved equal. Alternated sod variety shall be approved by the Campus Landscape Architect.

Landscape Accessories

- Concrete planters - Round and rectangular double rim planters in various sizes.
- Tree Grate – NEENAH FOUNDRY, [Model R-8707](#) Black Cast Iron.
- Pavers – as approved

Site Accessories:

- Bicycle Racks / Lockers: Bicycle accommodations shall conform to the Association of Pedestrian and Bicycle Professionals guidelines at <http://www.bicyclinginfo.org/engineering/parking.cfm>. Bicycle related signage shall conform to the Manual on Uniform Traffic Control Devices (MUTCD).
- General Guidelines for bicycle parking facilities should conform to the following minimum standards:
 - Provide at least 1.0 bicycle spaces per unit for residential buildings with more than 10 units.
 - Provide 1 bicycle space for every 15 regular building occupants per office, commercial or recreational facility.

Bike racks.

- BRANDIR, New York (212) 505-6500e Original Ribbon Rack, Size and number dependent on site requirements, stainless steel finish.

Bus Shelters

- Bus Shelters - TOLAR MANUFACTURING COMPANY, Inc. Signature Shelter, Non-AD Sunset Shelter (<http://www.tolarmfg.com>) or approved equal. Install either the 10' or 18' model as determined by site location and ridership. Bus shelter shall have a curved linear aluminum panel roof; a ¼" clear polycarbonate back wall, and full end panel walls with clear 3/8" thick tempered glass panels. The structure and roof shall be a dark bronze powder coat finish.
- Benches in the shelter shall be 6' steel strap bench without a back by TOLAR MANUFACTURING COMPANY, Inc. or approved equal. Color shall be a dark bronze, powder coat finish.
- The shelter shall incorporate into the design space for ADA accessible wheel chairs.

Fences and Gates

- Ornamental Fencing: most area fencing shall be ECHELON II Ornamental Aluminum Fence with Majestic style panels by AMERISTAR FENCE PRODUCTS (<http://www.ameristarfence.com>) or approved equal with a black powder coat finish. Height shall be determined by location and need.

- Chain-link Fencing: Where chain-link fencing is required around areas such as parking lots, utility installations, or service areas, the fencing shall be black vinyl coated chain-link. Height of the fencing shall be determined by location and need. The fencing system shall be 2" x 9 Ga., 1 5/8" O.D., schedule 40 galvanized top rail, 2.5" O.D., schedule 40 galvanized post and cap line post, 3" O.D., schedule 40 galvanized post and cap end post, crimped, 6 Ga., thermally extruded tension wire and a minimum 3,000 PSI concrete footing for each post.

Recreational Facility and Playground Equipment

- Playground equipment - type as indicated on drawings.

Signage

Exterior Wayfinding Signage shall be in accordance with the University of Memphis Exterior Signage and Landscape Master Plan, 2012.

Site, Street and Mall Furnishings

- Standard bench – LANDSCAPE FORMS INC. "Hyde Park" model. Rod seat insert design in a "Stormcloud" (dark bronze) color; 75" in length and securely mounted with stainless steel tamper proof bolts on a level, 3'x7'x4" deep concrete pad with turn down edge, steel trowel finish, on existing grade requiring no site work or landscaping when located in a lawn area.
- Bench – LANDSCAPE FORMS, INC. "Presidio Bench" without back and no arms, embedded mounting, color to be "Storm Cloud".
- Benches as part of a new building development may be used in reflecting the architectural style of the building but must be approved by the Campus Landscape Architect.
- Benches of wood or wood components are not acceptable.
- Backless and armless benches are only acceptable when used in bus shelters.
- Tables and chairs – LANDSCAPE FORMS INC. "Carousel Table" with attached backed chairs shall be the campus standard. Seating determined per individual installation needs/ requirements. Coating shall be a powder coat finish in "Stormcloud" (dark bronze) color. Table shall be securely surface mounted with stainless steel tamper proof bolts on a level concrete surface. Removable umbrellas may be used as circumstances dictate. Fixed metal umbrellas are not acceptable. Where tables and chairs can be secured or require a more flexible seating arrangement, the 30" LANDSCAPE FORMS "Traverse" table and armless metal grid chairs in Stormcloud color shall be used. These moveable table and chairs complement the Carousel model, but have a lighter silhouette and allow for more flexible seating arrangement.
- Trash and Ash Receptacles - (side opening with ash receptacle on top), dark bronze.
- Trash Receptacle – LANDSCAPE FORMS "Chase Park", 40 gal., side-opening style, keyed lock, surface mounted, "Stormcloud" powder coat color finish shall be the campus standard. The trash receptacle shall have a covered top and in 40 gallon side-opening style.

- Recycling Receptacles - New receptacles shall be “Chase Park” with high performance, exterior grade, UV protected, printed, vinyl label signage mounted securely on the sides. All trash and recycling receptacles shall be surface mounted with stainless steel tamper proof bolts on a level concrete surface.

Site Walls / Seat Walls / Retaining Walls

- Site walls may be used to retain grades, define building entrances, terraces, landings and ramps, screen service areas and utility appurtenances, define campus gateways or edges, and as seat walls at campus gathering areas.
- Site walls to be constructed of durable high-quality masonry. Materials, color, and workmanship of site walls built in association with buildings should closely match the quality and finishes of building walls. Bare concrete walls should be avoided: IF necessary for cost reasons, careful patterning of joints, cap and other detailing to be used to add scale and a higher level of finish.
- Seat walls are a way to create informal meeting and gathering places at locations that attract people, such as building entrances and intersections of major walks. They should be generously sized to allow comfortable, informal use.
- Seat wall shall be 18” deep minimum. Design copings in proportion to each wall. Seat walls shall be 12-18” deep and 15-20” high where ever adjacent grades allows. Walls should be higher in elevation than adjacent planted areas where applicable. Walls should have weep age adequate for surrounding soil conditions.
- Seat wall shall have a precast concrete coping with a minimum 1% cross-grade to allow positive drainage. Also design a 1”x1” recess at 4”o.c., the width of the seat wall as a skate board, rollerblade deterrent.

Walk, Road, and Parking

- Parking Gate: [AMANO McGANN “AMG-1750”](#)
- Parking Gate Controller: [DSX ACCESS SYSTEMS, INC. “DSX-1022 Intelligent Controller”](#)
- Parking Controller Server – [DSX ACCESS SYSTEMS, INC.](#)
- Parking / Access Control / Intrusion Detection Security System - Section 281000 Specification, [DSX ACCESS SYSTEMS, INC.](#)

Traffic Control Bollards

- Where unauthorized vehicular traffic on campus walkways and service drives requires control, card gates or removable bollards should be employed.

Campus Driveway Applications:

- [RELIANCE FOUNDRY “R-7901”](#) with removable receiver with lid or approved equal. Bollards shall be steel, 36” height with a 4.3” base with a polyester powder coat finish in dark bronze.

Bollard receiver shall be embedded in a concrete footing according to manufacturer's specifications. Click link above and / or see Installation drawing below.

Bollard Post, Model R-7901

General Description:

Clearly communicate intended routes and access regulations on your streetscape with the model R-7901 steel bollard from Reliance Foundry. Composed of standard steel and finished with a durable powder-coating, it is an aesthetically versatile device that will complement the architecture of almost any site. The R-7901 can be installed with a standard fixed mounting or with a removable or fold down mountings that allow temporary access to maintenance, delivery or emergency vehicles. Seven powder coating color options are available and the model R-7901 is kept in stock, available for immediate shipment. For more information on bollard post installation, please visit: <http://www.reliance-foundry.com/bollard/installation-bollards>

Specifications:

Height: 36"
 Base Diameter: 4.3"
 Weight: 38 lbs (Bollard Post)
 Material: Steel (ASTM A36)

Finish Options:

✓ Polyester Powdercoated
 See Reliance Foundry's standard color options at <http://www.reliance-foundry.com/bollard/installation-bollards>

Mount Options:

✓ Removable Receiver with Lid (see sheet 2 of 7)
 ○ Removable Receiver with Chain (see sheet 3 of 7)
 ○ Fixed Embedded Mount (see sheet 4 of 7)
 ○ Flanged Surface Mount (see sheet 5 of 7)
 ○ Fold Down Mount (see sheet 6 of 7)
 ○ Optional Chain Accessory (see sheet 7 of 7)

Removable Receiver with Lid
(For important detail regarding installation with OPTIONAL bollard chain accessories, refer to sheet 7 of 7)

Notes:

- Embedment details are for reference illustration only. Minimum foundation sizes depend on local soil conditions, weather conditions, and engineering requirements.
- Bollard post is provided as shown, with material detailed in legend below. Concrete, foundation and/or installation ordered separately or provided by others.
- This drawing is not drawn to scale. Dimensions provided herein is for reference only. Please consult Reliance Foundry sales professionals if any dimension is critical to your particular installation.
- Reliance Foundry reserves the right to amend design and specifications without prior notice for product improvement.

PARTS LIST						
ITEM	QTY	PART NUMBER	DESCRIPTION	MATERIAL	WEIGHT	
1	1	R-7901	Bollard Post	Steel (ASTM A36)	38 lbs	
2	1	R-7901-R	Removable Receiver with Lid	Galvanized Steel, c/w SAE 304 Stainless Steel Cover	22 lbs	
3	1	Padlock (Optional)	Optional Padlock (Regular or Marine Grade)	Regular-Brass, Marine-Brass w/ Chrome Plating		

Unit 207, 6450 - 148 Street, Surrey, BC V3S 7G7, Canada
 1-888-735-5680 info@reliance-foundry.com
<http://www.reliance-foundry.com>

TITLE
Bollard Post, Model R-7901

SIZE: C DWG NO: R-7901 REV: B

NOT TO SCALE SHEET 2 OF 7

Decorative Bollards

- In some areas where the traditional bollard/traffic control bollard may not be compatible in design with its surroundings, decorative pedestrian bollards may be considered as an alternative. Determined by location and need, these bollards may be either lighted or non-lighted.
- Alternative decorative bollards shall be as follows, or approved equal.
- KING LUMINAIRE, Model KL-A-AL-LED, 8" diameter base, smooth aluminum LED light bollard with external louver and internal acrylic lens, integral ballast, base plate with decorative cover and a powder coated finish in a dark bronze color.
- LANDSCAPE FORMS "Annapolis"; low voltage LED light bollard, 6" diameter, embedded mounting and a powder coated finish in a dark bronze color - "Storm Cloud".
- Bollards - ANTIQUE STREET LAMPS, INC. Austin, TX. (512) 282-9760. Penn series #BOL/P32/10/BT-CA/DB, cast aluminum, powder coated, dark bronze finish.
- Pipe Bollards - 7"x 6" diameter. Sink in ground 12"-18" and anchor in, and fill, with concrete.

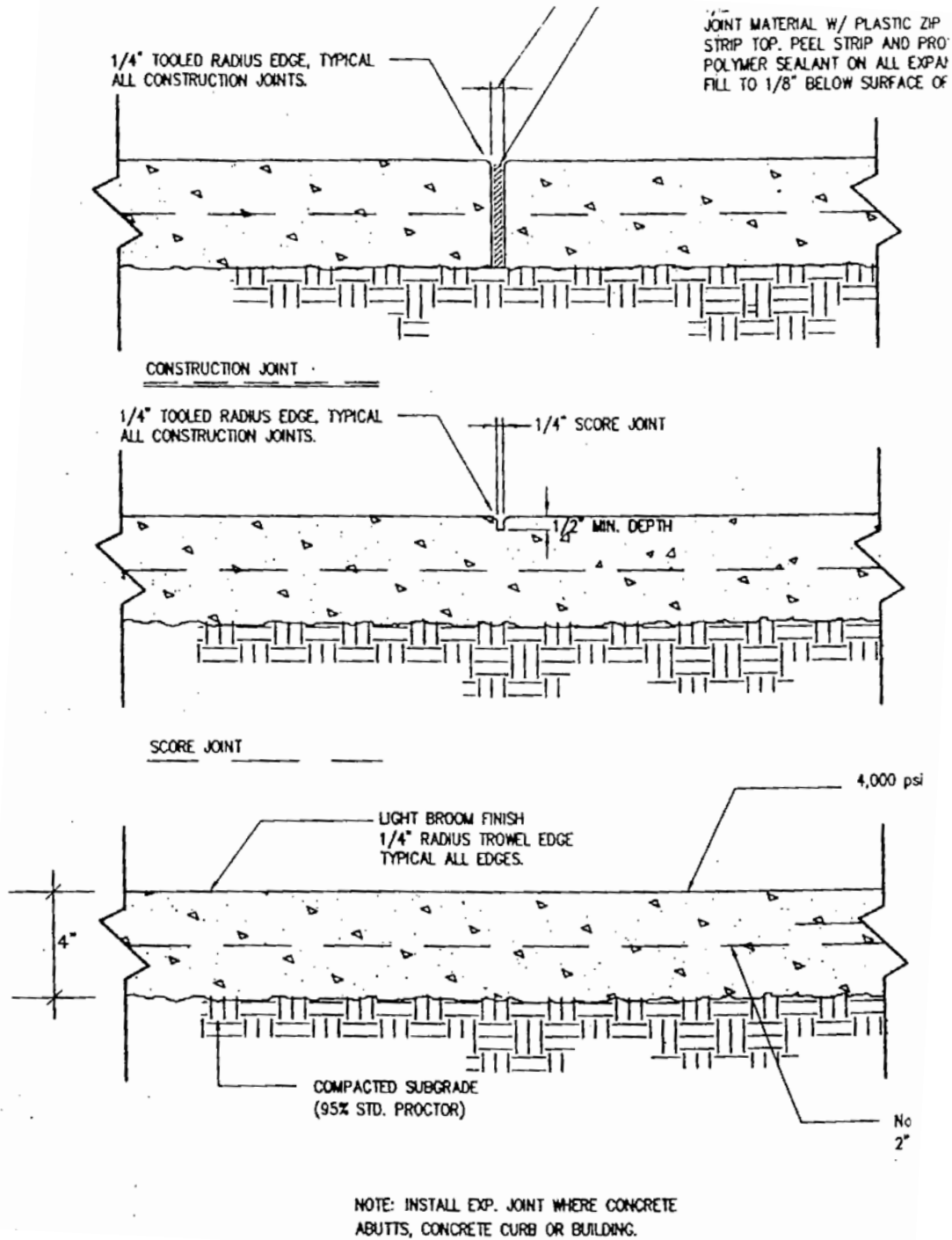

• 4" CONCRETE SIDEWALK / PAVEMENT

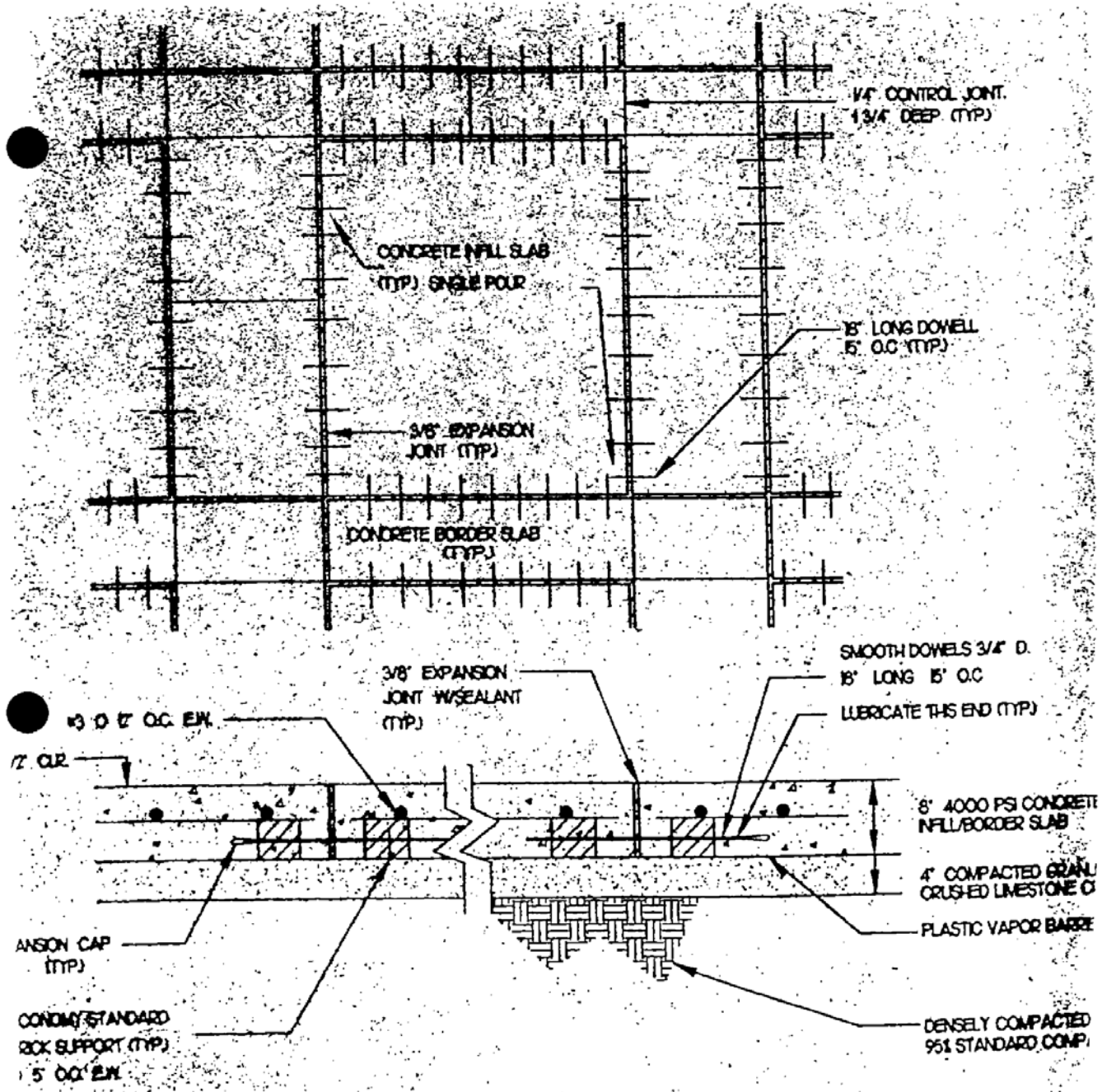

• PEDESTRIAN WALKWAY PAVEMENT PATTERN DESIGN

- Inlets

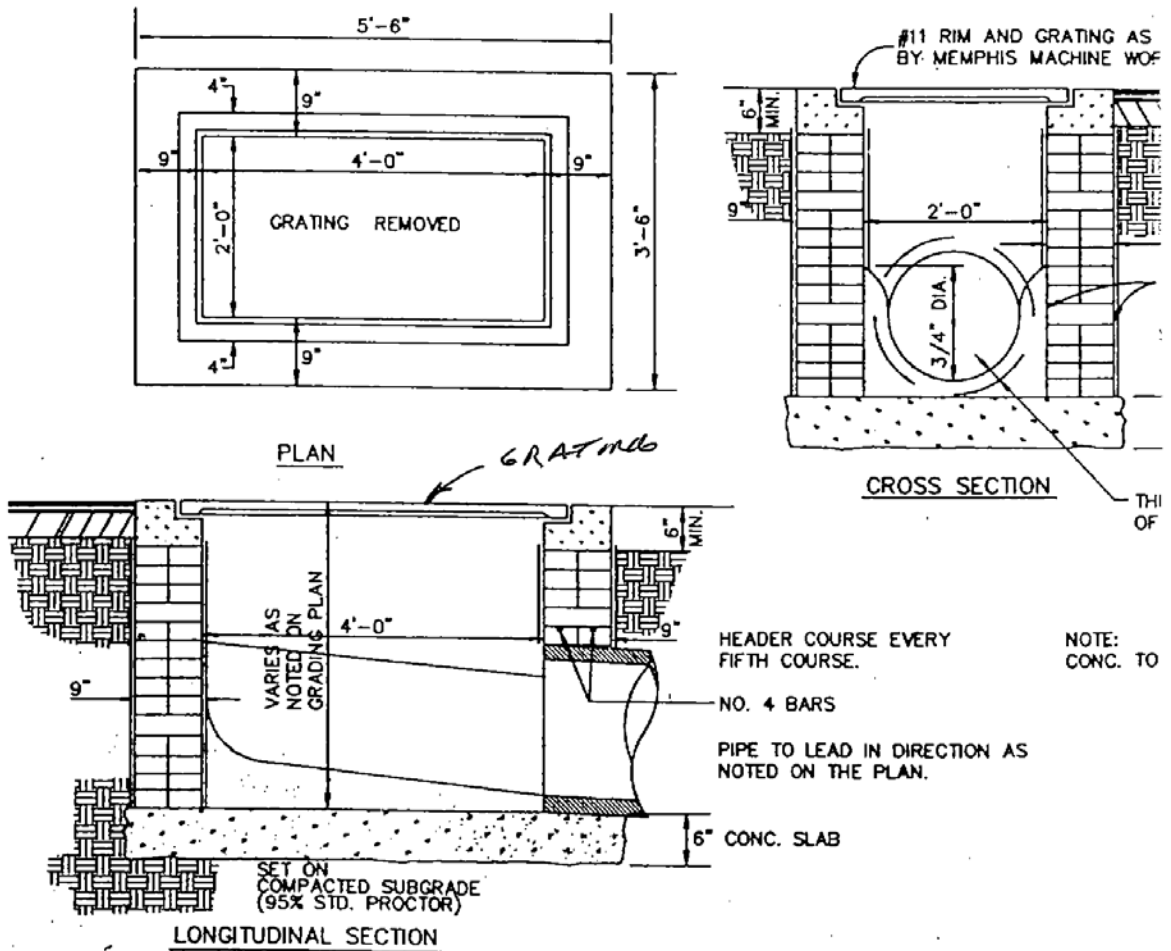

• **NUMBER 11 INLET**

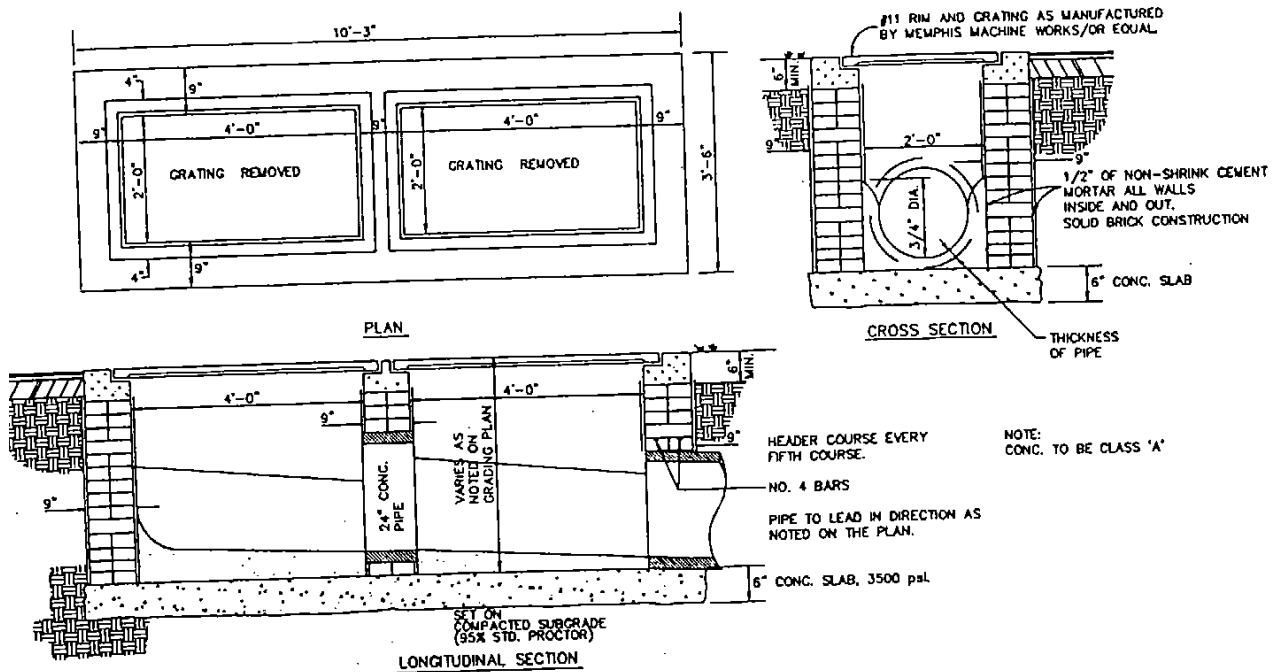

• **TWIN NUMBER 11 INLET**

- Parking lot design, including lighting fixtures and levels, access and egress, fire lane requirements, landscaping, islands, curbs, and wheel stops to be considered in final design.
- Road and parking lot pavements shall be impervious asphalt (bituminous concrete); pervious asphalt (bituminous concrete) or pervious concrete.
- For all road and parking additions or replacement projects alternative methods of reducing water sediments and pollutants should be evaluated to determine preferred water quality improvement techniques for the specific project.

- **Asphalt**

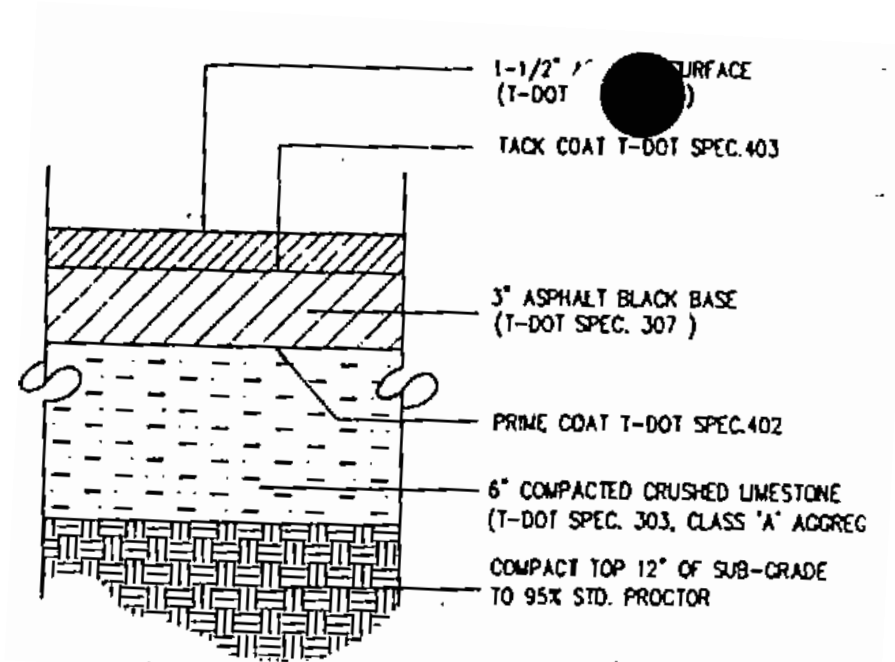

- **ASPHALT PAVEMENT AND BASE**

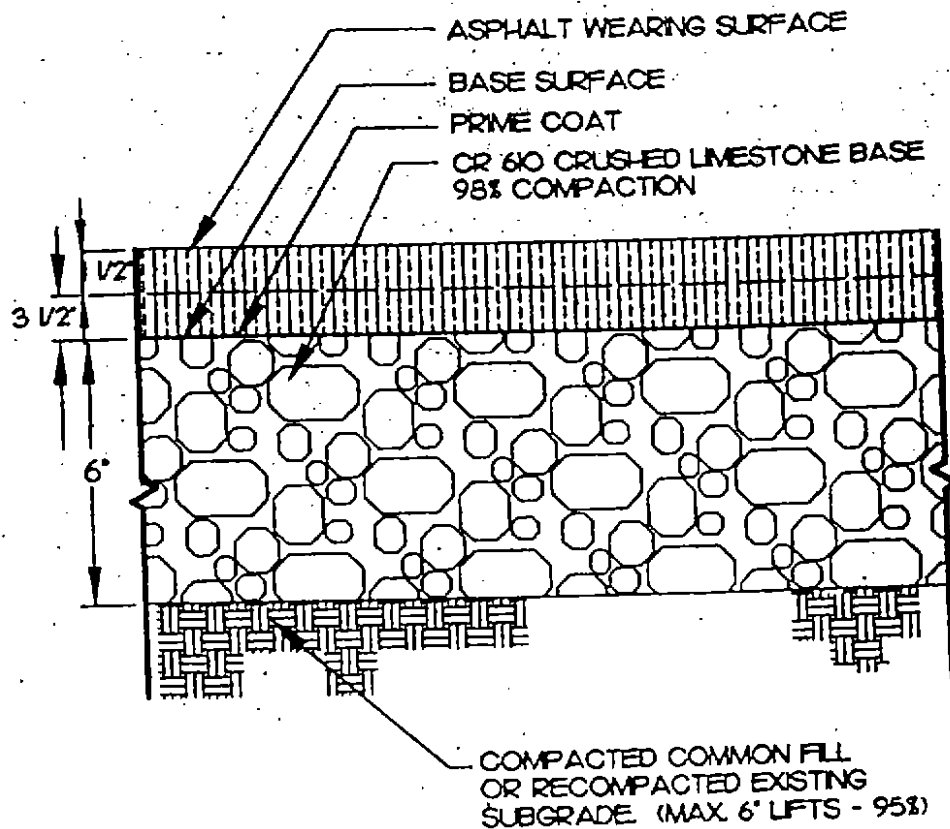

• **ASPHALT PAVEMENT (HEAVY-DUTY)**

Crosswalks

- -Crosswalks shall be demarcated with white, preformed melt down thermoplastic striping. Striping pattern shall consist of broad white stripes parallel to the direction of the vehicular movement and framing white bands perpendicular to the direction of vehicular movement.
- -Crosswalks dimensions shall adhere to the City of Memphis Traffic Engineering Standards and the Manual on Uniform Traffic Control Devices (MUTCD).
- -Campus standard pole mounted pedestrian or street light fixtures should be located in the lawn or sidewalk close enough to the crosswalk to make crossing pedestrians visible to drivers. Light fixtures adjacent to crosswalks should be part of a regular spacing of lighting along the length of the street.

Curbing: Street, Medians, and Parking Lots

- -Street Curbing – street outside edge curbing is a concrete 6-30 curb & gutter conforming to the City of Memphis Design Standards.
- -Median Curbing – street median curbing is a concrete 6-18 curb & gutter conforming to the City of Memphis Design Standards.
- -New Parking Lot Curbing is a concrete 6-18 curb with rebar.

- -Rehabilitation of Existing Parking Lots is a concrete extruded 6" curb with rebar pegs a minimum 5' on center

Curb Ramps

- Curb cuts and curb ramps shall be provided along all barrier free routes as required and shall conform to ADA and ABA standards (<http://www.access-board.gov/ada-aba/final.cfm>).
- Where feasible, curb ramps shall have a wide gradual apron; ramp width shall be determined on a case by case basis considering factors such as pedestrian safety, width of connecting sidewalks, and utility/pole locations.
- Curb ramps shall have detectable surfacing conforming to the City of Memphis Design Standards.

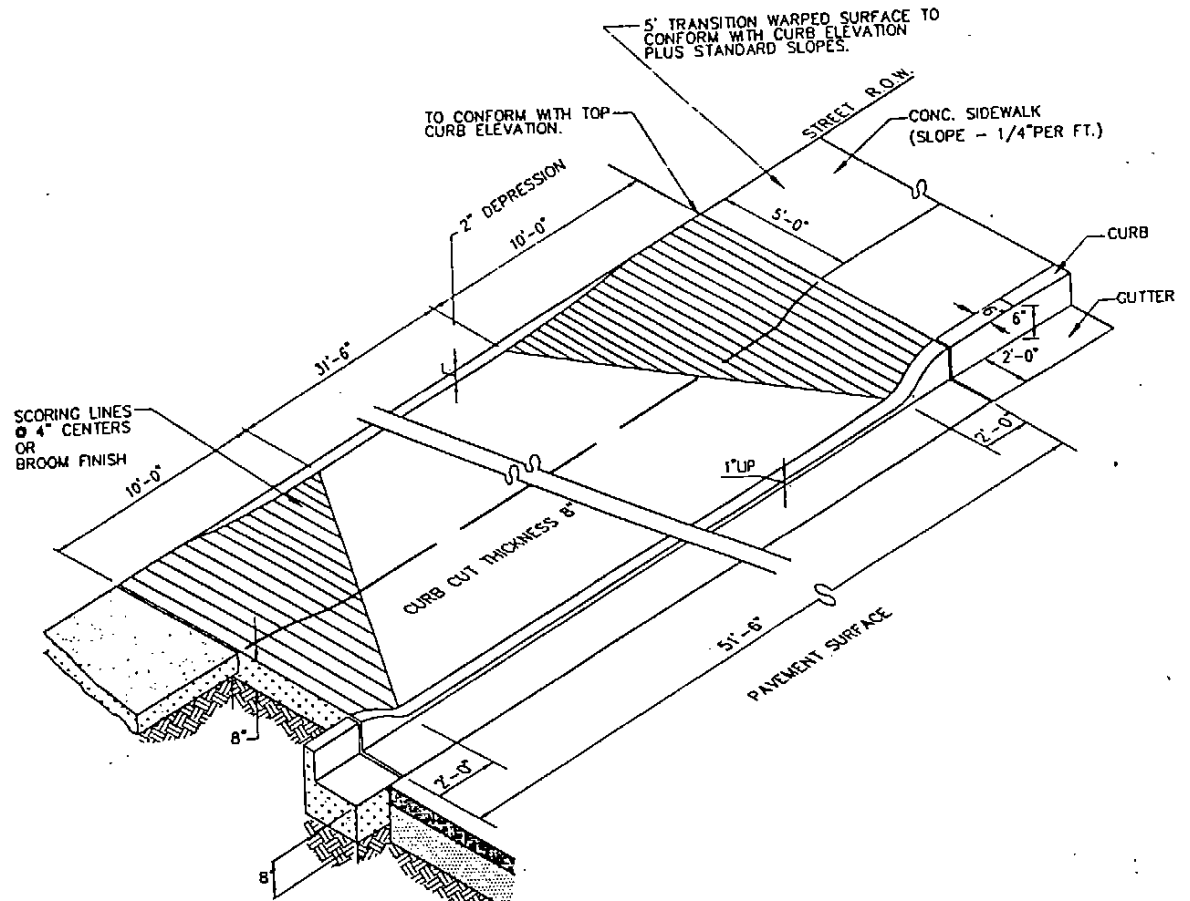

COMMERCIAL CURB CUT

Walk Pavements and Handicap Access Ramps

- The preferred material for campus sidewalks is cast in place concrete. The panels shall consist of a center panel of exposed aggregate concrete with light broom finish concrete bands.
- The distance between concrete bands should vary from 10 to 15 feet, depending upon the design context.
- The width of the broom finished bands varies with the width of the sidewalk. The band width is based on 18% of the overall width of the sidewalk.
- For accessibility purposes all walks should maintain the following unobstructed widths:

- Primary Walkways: 21 to 25 feet
- Secondary Walkways: 11 to 20 feet
- Tertiary Walkways: 6 to 10 feet
- Walk width shall vary with the volume of pedestrian traffic, with six feet being the minimum and used in only very low volume areas; eight feet width being the standard for most campus applications where occasional service vehicle use is anticipated.
- No walkway should maintain a slope of greater than 4.99%.
- Pavement thickness on all walks shall be a minimum of 5" thick for light duty pedestrian walkway. Where walkways are designated to be heavy duty, the minimum thickness shall be 8" thick.
- All walkway designs should eliminate tight, hard-to-manuever corners. All walkway intersections should have a minimum of a 5 foot radius.
- Handicap access ramps shall also be construct in cast in place concrete and shall conform to ADA and ABA standards

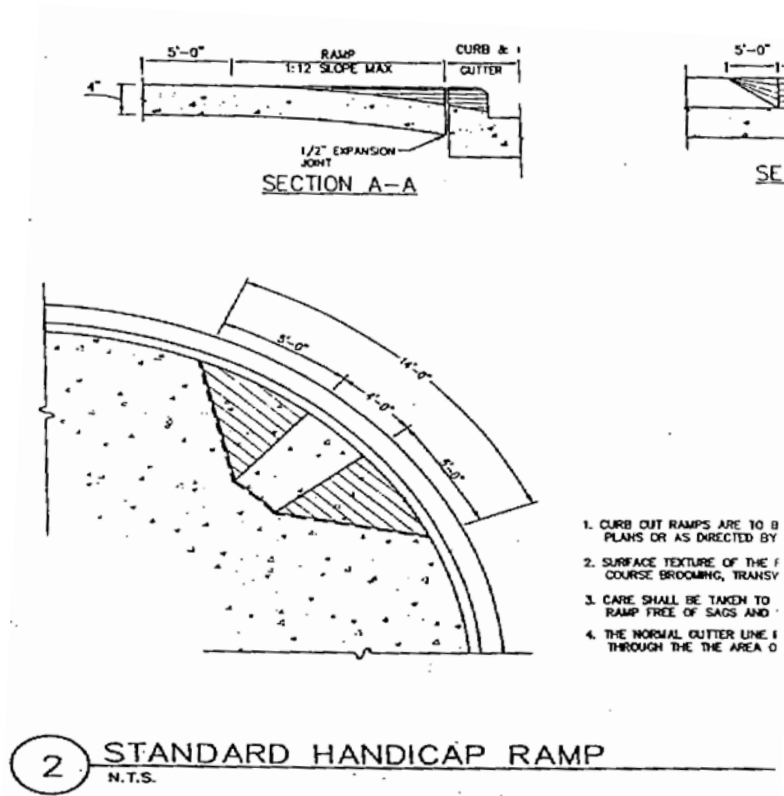

Special Pavements

- On major pedestrian walkways special pavement may be used to add visual richness and improve pedestrian scale. Other appropriate applications include service areas that double as pedestrian

routes, campus gathering spaces and plazas, areas associated with building terraces and entrances, street crosswalks and commemorative pavers located in plaza areas.

- Pavement patterns within special pavements should be kept simple and relate to immediate context.
- Pervious special pavers should be considered as a means of infiltrating storm water. Factors to consider should include subsurface soil conditions, maintenance implications and cost effectiveness versus other available storm water management methods. Special pervious paver shall be of high quality material and compatible with adjacent landscape and architectural materials. Pervious special pavers shall be 4"x8"x2.75" permeable clay brick in a random mix of antique, dark antique and re sunset colors by WHITARE-GREER or approved equal.

Storm Water

- Storm water management shall be in accordance with the NPDES Permitting process as required by the Tennessee Department of Environment and Conservation and the City of Memphis Storm Water Management and Pollution Control ordinances. The recommendations of the Storm Water Management Plan should be incorporated into the early stages of site planning and project design.
- Drainage piping –concrete piping only
- Striping – thermoplastic

Carpentry and Painting:

Ceilings

- Acoustical Ceilings – Install 2' x 2' grid and tiles for NEW installations, 2' x 4' ONLY to match existing.
- Acoustical Tile
- Existing - Match existing building, salvage from demolition area if in acceptable condition, replace as necessary where existing panels are damaged or missing.
- 2' x 2' x 5/8" fissured – ARMSTRONG Fine Fissured Square Lay-In #1728, 2' x 2' x 5/8" for 15/16" grid. White.
- LAY-IN CEILING PANELS (SPECIAL APPLICATIONS)
- 2' x 2', high moisture areas (shower rooms) – ARMSTRONG Travertine Ceramaguard RH100 #601, 2' x 2' x 5/8" lay-in FireGuard (UL), perforated, white, high-density ceramic/mineral fiber composite, ASTM E1264.
- Gypsum-Panel Textured Ceilings - NO Gypsum board ceilings are to be installed unless specifically approved, NO SUBSTITUTION.

Doors

- All interior doors, whether oak, birch, or maple to be stain grade wood with matched veneers. No painted interior wood doors to be used.

Security Glazing

- **Security vision light** - OMNILITE FR-45 7/8" thick tempered glass. **Frame** - ANEMOSTAT # FGS-IS, metal UL or WHI approved frame provided with tamper resistant fasteners. Frame color: Gray Primer.
- NOTE: Fabricate, machine, and install according to manufacturer's instructions, approved shop drawings, and submittals. Use screw applied stops and tamper resistant fasteners.
- Downspouts – metal with baked enamel finish
- Fire doors – metal only, no wood fire doors, painted.
- Gypsum board partitions
- All new permanent gypsum board partitions shall extend to concrete ceiling/deck and be 1 or 2-hour class as required.
- All gypsum board to be 5/8" fire rated or 5/8" moisture proof, fire rated unless noted otherwise.

Stairs

- Exterior stairs - cast-in-place concrete with metal step nosing.
- Where stairs occur in lawns, cheek walls shall be parallel and equal to surrounding grades for ease of lawn mowing and to visually minimize steps and enhance the continuity of the lawn. Where stairs occur at plant beds, cheek walls shall not be used.
- Stair Nosing - BALCO, INC. Cast aluminum stair nosing, SN 055500; single component, aluminum, non-slip or approved equal.

Handrails and Railings

- Handrails – Use only welded 1-1/2" outside diameter stainless steel pipe, mill finish, all wall brackets, fittings, fasteners and connections to be nonferrous components. Locate all brackets at spacing required for design loading. Exterior rail color to be clear anodized. NO dark bronze rails are to be used on exterior sun exposed locations.
- Handrails, posts, and brackets shall be stainless steel #304 alloy with #4 brushed finish. All welds are to ground smooth.
- Handrails are to follow profile of steps, code required distance above nosing of each step.
- Posts shall be direct bury with 1/8"x3/4"x3 1/2" diameter stainless steel cover flange slip or epoxy in place.
- Intermediate posts and rails, where required, shall meet structural requirements and applicable standards, but should be kept to minimum to create a simple profile.
- Handrails should be mounted on cheek walls.

- Field measure, fabricate, shop prime, and install according to manufacturers' instructions, approved shop drawings, submittals, and all applicable code requirements of the *National Life Safety Standards*, *Americans with Disabilities Act of 1990*, and all local codes. In the case of substitution submit sample.

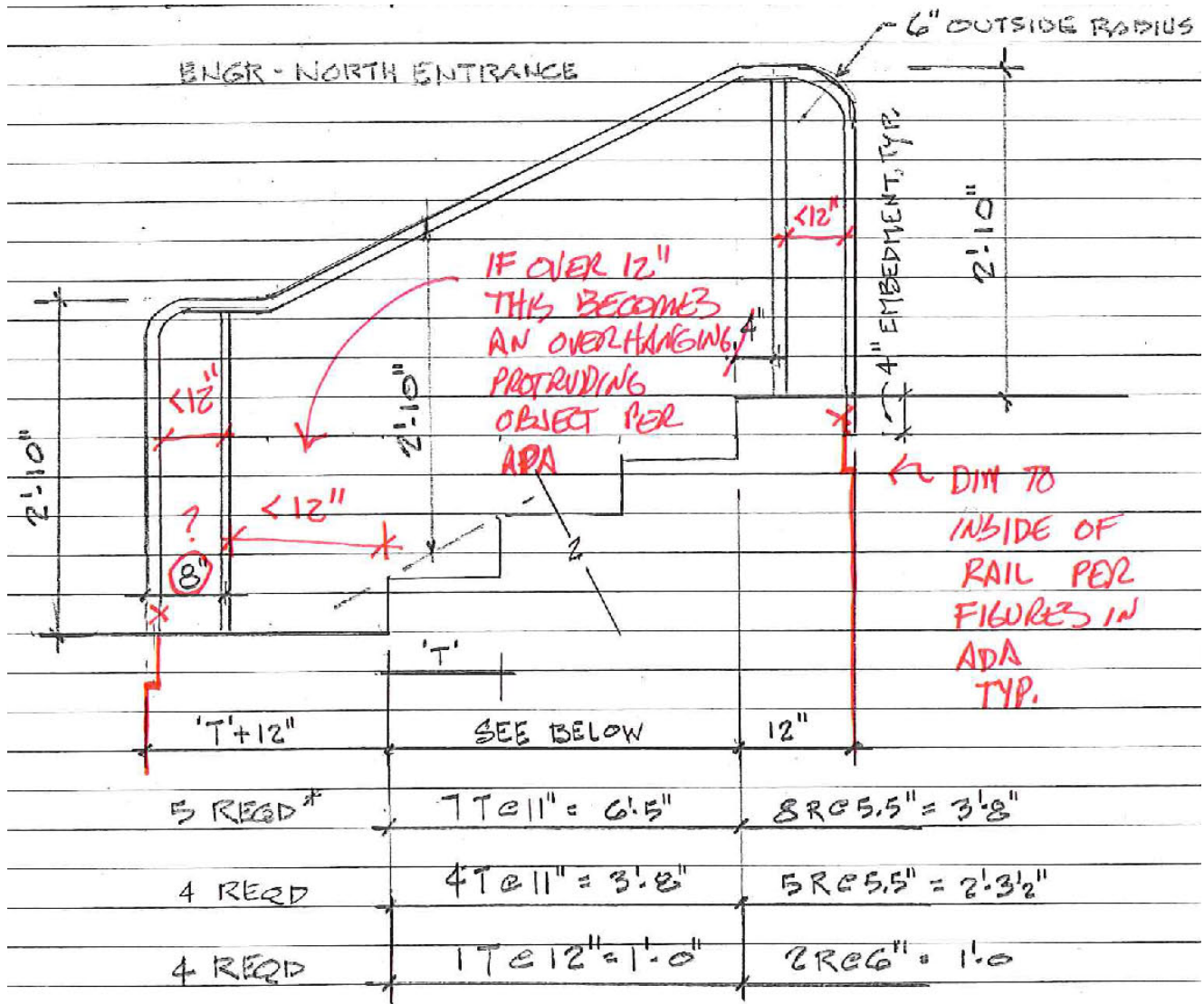

HANDRAIL DETAILS NO SCALE

* ONE SPECIAL END AT CORNER REQ'D
SEE SHEET 2

1. 1 1/2" ϕ STAINLESS STEEL w/ #4 FINISH
2. FIELD MEASURE CONDITIONS BEFORE FABRICATION.

COMMENTS
8/4/11

L. SCHULZ
8-3-2011

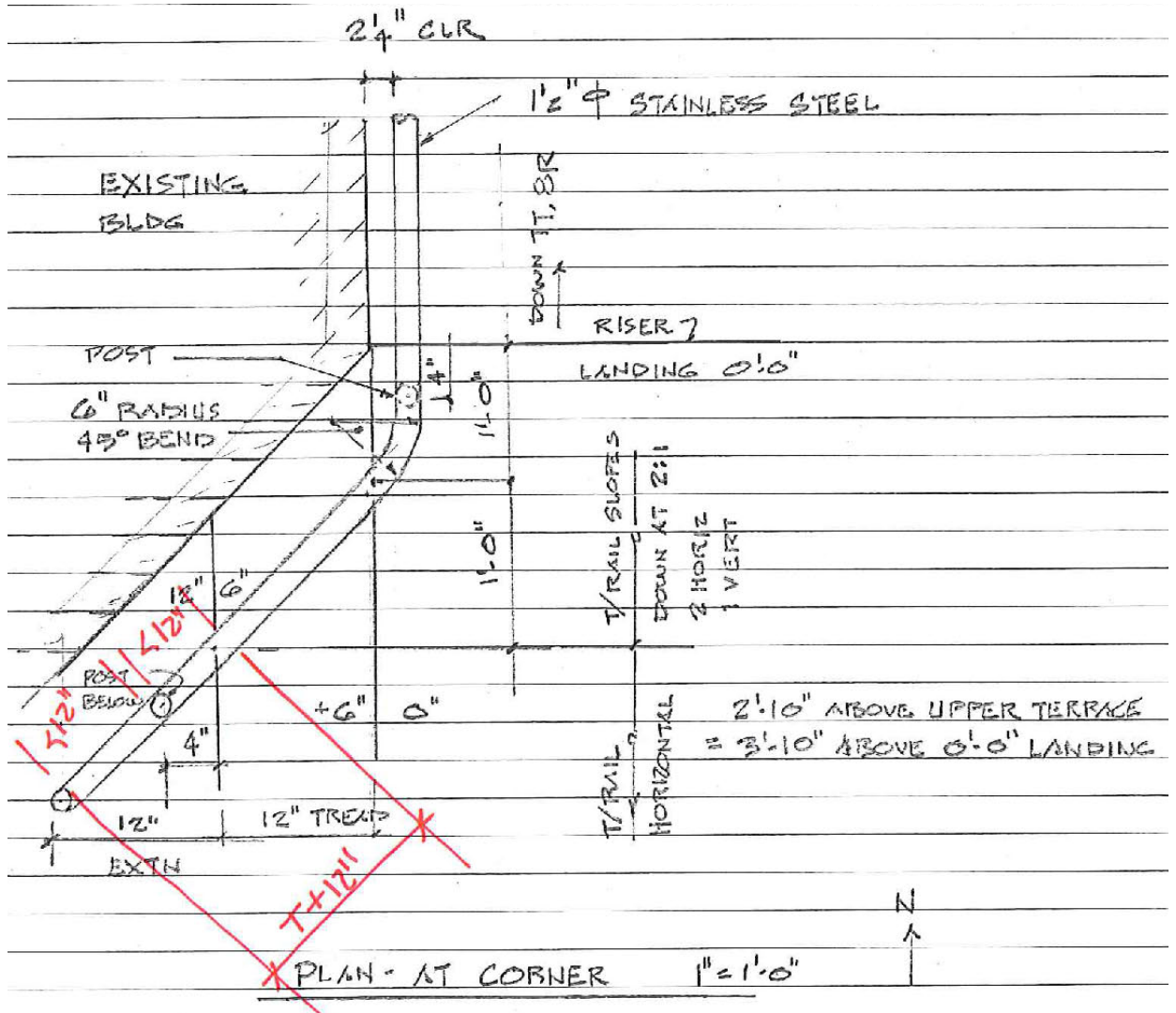

Interior painting

- Interior paint to be semi-gloss enamels for halls, restrooms, classrooms, and trim and satin finish for offices.

Exterior painting

- Utilize oil based enamel, colors approved by UM

- **Roofing** – use adhered epdm membrane to meet state standards.

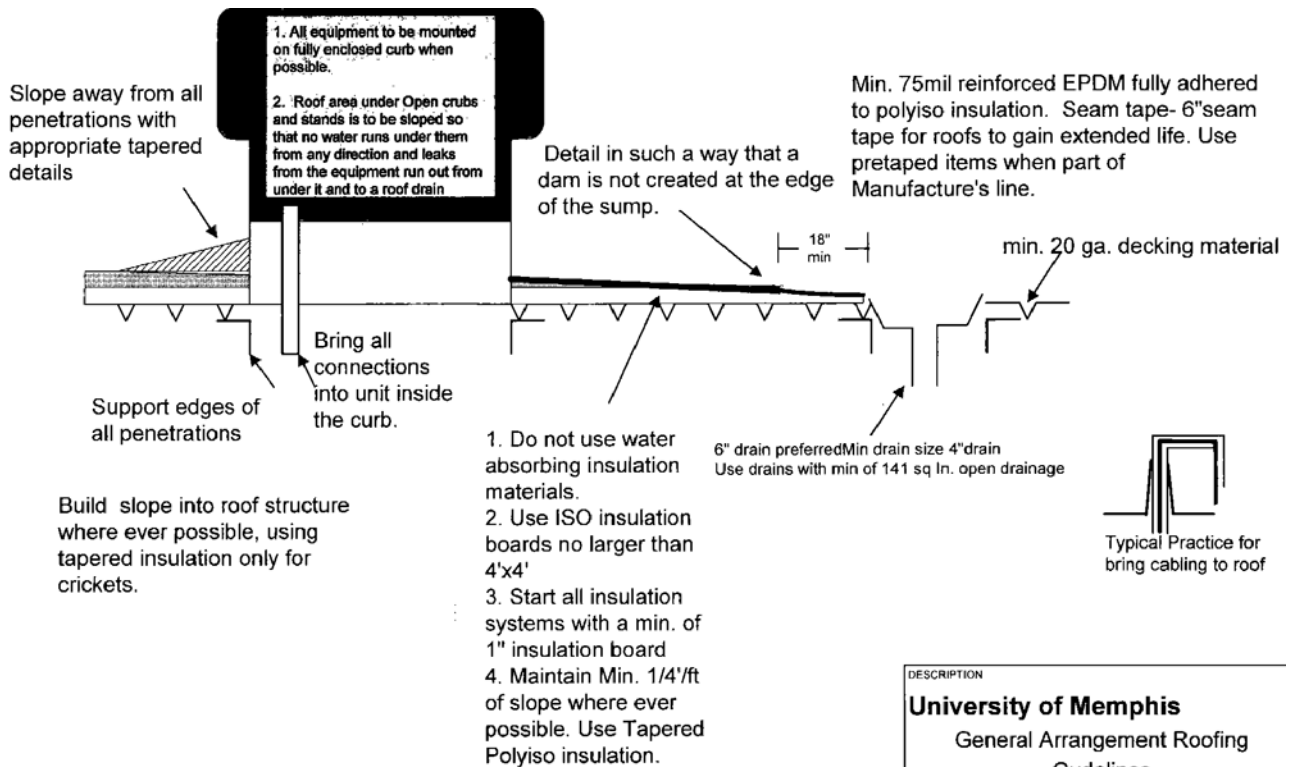
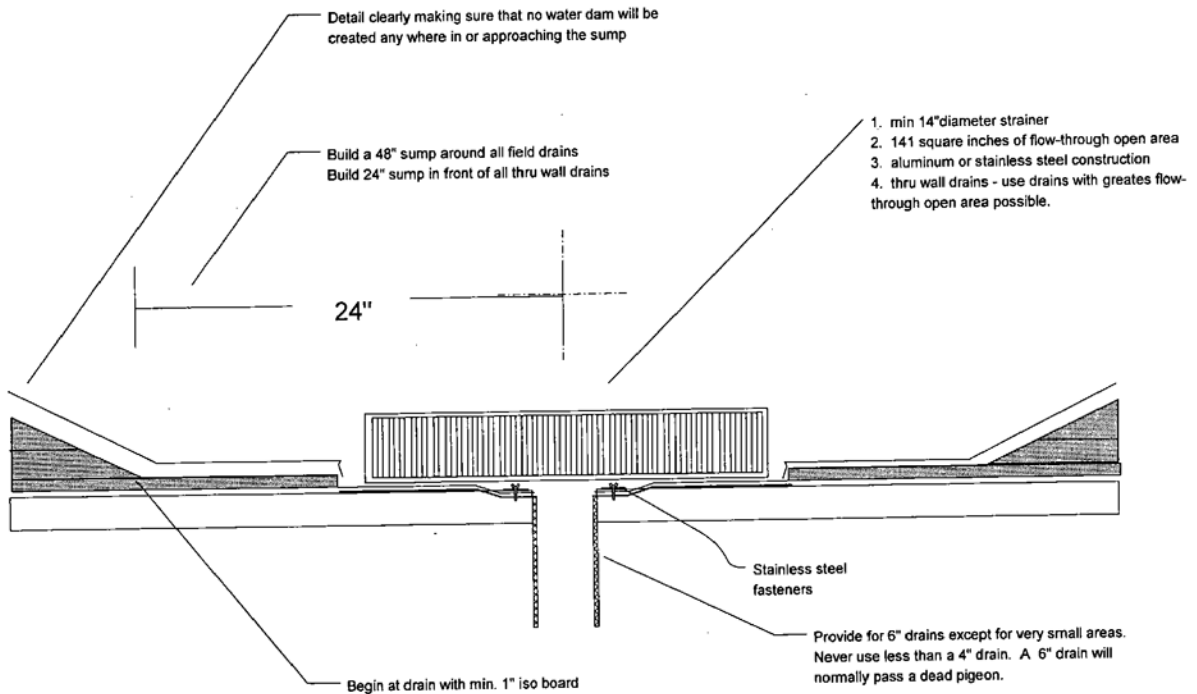

General Notes:

1. Build slope into roof structure where ever possible.
2. use asphalt to adhered insulation to concrete decks
3. Always design for as much slope as possible within project
4. Design new roof so that there is one manufacture warranty on the entire system.

DESCRIPTION
<p>University of Memphis General Arrangement Roofing Gudelines Jan 2001 William E Underwood</p> <p>These are general arrangement details. The designer is responsible for designing and detailing elements.</p>

Lock shop

- Door Hardware – BEST, VON DUPRIN
- Use new locks and hardware throughout; while matching University requirements.
- Do not use pivots, floor mounted closers, or concealed closers
- Finishes: as selected by the university
- Bronze colored storefront - all bronze except lockset, lever, and panic bar. Bronze plate behind panic bar
- Aluminum colored storefront - all stainless steel / aluminum
- Mortise locksets are standard, also spec BEST or CORBIN cylinders. Use cylindrical locksets only in a building with BEST master keys, to match existing locksets
- Pairs of doors with a fixed astragal have the same hardware as single doors.
- Double door standards: VON **DUPRIN 99 rim panics and removable mullions. NO vertical rods.**
- **VON DUPRIN exterior trim should be “NL” - night latch function.**
- Below is the preferred hardware to use on doors. Designer shall verify code requirements.
- NO “GE” access control products. The campus standard is STANLEY BASIS.
- Wide stile doors are required with rim panics and removable mullions.

Mortise Lock substitutions

<u>BEST number</u>	<u>CORBIN RUSSWIN number</u>
35H7E15J626	ML2051-NSM-626- (<u>HAND</u>) LC
35H7EW15J626	ML2057-NSM-626- (<u>HAND</u>) LC
35H7J15J626	ML2055-NSM-626- (<u>HAND</u>) LC
35H7EWEU15J626	

When CORBIN-RUSSWIN locks are used BEST mortise cylinders will have to be ordered. Hardware supplier is responsible for determining the proper cams for cylinders. BEST mortise cylinders are 1E74(CAM) RP3-626.

A. Single office doors not fire rated (Fire rated doors same but closer required)

- 1 - BEST lock set 35H7E15J-626
- 3 - STANLEY FBB179 NRP 4.5 X 4.5 hinges
- 1 - LCN 4041 closer (if needed)

B. Double office doors not fire rated (Fire rated doors same but closer required)

- 1 - BEST lock set 35H7E15J-626
- 3 - STANLEY FBB179 NRP 4.5 X 4.5 hinges
- 1 - LCN 4041 closer (if needed)
- 2 - GLYNN-JOHNSON FB6-626 manual flush bolts

C. Single storeroom and mechanical rooms

- 1 ea. BEST lock set 35H7Ew15J-626
- 3 ea. STANLEY FBB179 NRP 4.5 X 4.5 hinges
- 1 ea. LCN 4041 closer

D. Double storeroom and mechanical room doors

- 1 - BEST lock set 35H7E15J-626
- 3 - STANLEY FBB179 NRP 4.5 X 4.5 hinges
- 1 - LCN 4041 closer
- 2 - GLYNN-JOHNSON FB6-626 manual flush bolts

E. Classroom doors and multiple use bathrooms that require positive latching.

- 1 - BEST lock set 35H7J15J-626
- 3 - STANLEY FBB179 NRP 4.5 X 4.5 hinges
- 1 - LCN 4041 closer (if needed)

F. Single Fire doors (panic hardware required)

- 1 - VON-DUPRIN 99LF – 626 –
- 1 - PEMKO continuous hinge CFM (length in inches) HD (match color to door)
- 1 - LCN 4041 closer
- 1 - BEST cylinder 1E72-S2-626

G. Double fire doors (panic hardware required) (no astragal)

- 1 - VON-DUPRIN 9927LF-626 (HAND)
- 1 - VON-DUPRIN 9927LF-626-(HAND) DUMMY TRIM
- 2 - LCN 4041 closers

2 - PEMKO continuous hinges CFM (length in inches) HD (match color to door)

1 - BEST cylinder 1E72-S2-626

H. Double fire doors (panic hardware required, with astragal)

1 – VON-DUPRIN 9975LF-626 (HAND)

1 – VON-DUPRIN 9927LF-626-(HAND) DUMMY TRIM

2 - LCN 4041 closers

2 – PEMKO continuous hinges CFM (length in inches) HD (match color to door)

1 - Coordinator COR85-6261

1 - BEST Cylinder 1E74-C4-626

I. Single non-rated doors (panics required)

1 – VON-DUPRIN CD99L – 626 –

1 – PEMKO continuous hinge CFM (length in inches) HD (match color to door)

1 - LCN 4041 closer

1 - BEST cylinder 1E72-S2-626

J. Store front doors

1 – VON-DUPRIN EL3547L-626-HAND

1 – VON-DUPRIN EL3547L-626-DUMMY TRIM-HAND

2 – VON-DUPRIN power transfer EPT-218 (match color to door)

1 - BEST switch lock 1W7B2-626 (mounted on inside jamb tube or in electric box inside in wall)

1 - BEST cylinder 1E74-C4-626

2 - LCN 4041 *CUSH-N-STOP* (match color to door)

2 - PEMKO continuous hinge CFM (length in inches) HD (match color to door)

1 EA for up to four panic bars power supply VON-DUPRIN mini power booster PS-873-4

Door to be US ALUMINUM or VISTAWALL with rolling astragal.

IF a handicapped opener is required DELETE one closer and ADD the following items:

1 – DOOR-A-MATIC *SENIOR* swing operator with (hand) out swing arm

1 - STANLEY lock relay board

2 – WIKK 4” square stainless steel push plate with handicapped logo

2 – WIKK 300 MHz radio transmitter (delete if buttons can be hard wired)

2 – CURRAN radio receiver (delete if buttons can be hard wired)

1 – 24-volt transformer (delete if buttons can be hard wired)

1 – POTTER & BRUMFIELD *KRPA-14DG-24* triple pole double throw relay (substitutions must use the same base)

K. Door closer substitutions

1. All door closers shall be cast iron cylinders, with seasonal fluid; non-handed, with field adjustable size.
2. Due to restraints on repairs to fire doors, screw patterns shall match LCN 4041.
3. Substitutions **MUST** be approved before being installed and used.
4. Provide one sample to the University lock shop for testing *prior to* submittals.

L. Exit Devices

1. **Panic bar substitutions** - Any substitution to be equal to VON-DUPRIN panic listed. Provide one sample to the University lock shop for testing *prior to* submittals.

M. Sliding and Folding Door Hardware

1. **Sliders** - STANLEY *Dura-Glide 3000* (or equal) with electric locking Fail secure

Electro- Mechanical Hardware

A. Rooms with card reader (networked system, panic not required)

1 - APPLIED REALTIME SYSTEMS *IQ2000* reader

1 - BEST lock set 35H7EWEU15J-626

1 - 24-volt transformer.

2 duplex receptacles inside room above ceiling spaced at least 6 inches apart.

1 - AXIS 560 print server

1 - LCN 4041 door closer.

Cat 6 wire - four pair from above ceiling inside room to location of reader head outside room.

Cat 6 wire - four pair from above ceiling inside to nearest computer hub not to exceed 300 feet

B. Rooms with stand-alone card reader (Substitutes **MUST be able to use VINGCARD campus 2000 software)**

1 - VINGCARD *PERSONA* lock set 32K x ships lever x hand.

1 - LCN 4041 closer (optional, but recommended)

C. Door openers

1. Openers to be mechanical in design with safety controls that reverse direction when door meets obstructions.

2. Openers shall have field selectable switches that allow set latch speed, back-check speed, push-to-open, power boost for 5 seconds selections.
3. Gear boxes motors and control panels shall be stocked in the Memphis area for emergency repairs.
4. Provide one sample to the University lock shop for testing prior to submittals.
5. The Bosch Request to Exit sensors are NOT desirable. The hand wave sensor is sufficient to operate the automatic operators.

ADA Electro- Mechanical Hardware by STANLEY ACCESS TECHNOLOGIES LLC

OPTION #1

- 1 ea. Magic Force Swing Door Operator
- 1 ea. Magic Force Single Control (MC521)
- 1 ea. Magic Force Door Arm Linkage 11", Clear
- 1 ea. Magic Force Outswing Door Arm, Clear
- 1 ea. Magic Force Vis Hdr Spec Width: 0"-51", Clear
- 1 ea. BEA 10BR3 PROG 3-RELAY LOGIC MODULE
- 1 ea. BEA REL24VDC DPDT ISOLATION RELAY DC
- 2 ea. MSS 216 INFRARED TOUCHLESS DOOR SWITCH

Item "216 TLPP" is manufactured by MS SEDCO and is the wired, touchless, infrared push plate. The relay module is for interfacing the exterior push plate with the building access control system so when the doors lock the exterior push plate is turned off.

Scope of Work:

We will furnish and install (1) single Stanley Magic Force operator in a clear anodized header and two touchless push plates for activation. The operator will be set up to meet ANSI A156.19 Standards for Low Energy Operation. Relay included to work with card reader.

OPTION #2:

- 1 ea. Magic Force Swing Door Operator
- 1 ea. Magic Force Single Control (MC521)
- 1 ea. Magic Force Door Arm Linkage 11",
- 1 ea. Magic Force Outswing Door Arm, Clear
- 1 ea. Magic Force Vis Hdr Spec Width: 0"-51",
- 1 ea. BEA 10BR3 PROG 3-RELAY LOGIC MODULE
- 1 ea. BEA REL24VDC DPDT ISOLATION RELAY DC
- 2 ea. MSS 216 INFRARED TOUCHLESS DOOR SWITCH
- 1 ea. VD EL Rim Panic

Scope of Work:

We will furnish and install (1) single Stanley Magic Force operator in a dark bronze anodized header and two touchless push plates for activation. The operator will be set up to meet ANSI A156.19 Standards for Low Energy Operation. Von Duprin electric rim panic hardware with trim is included for the door.

Heating, Ventilation, and Air Conditioning (HVAC)

Environmental Conditions and General Design Requirements

- Final design of the energy management system (EMS) or building automation system (BAS) to be evaluated, reviewed, and approved in writing by the University before proceeding to Contract Documents.
- Normally conditioned spaces (e.g. offices and classrooms) design requirements for normal operating hours to be 72° F. ($\pm 2^\circ$) dry bulb temperature with 45% to 60% relative humidity.
- Verify design requirements for laboratory, archival, computer, and etc. spaces. For Lab Standards see lab design section of this document.
- Size the building chilled water system according to a 50°F leaving water temperature from the central heating/cooling plant.
- Primary cooling to be provided in the following two ways:
 - During summer months, chilled water to be supplied from the central heating/cooling plant via a chilled water transmission system.
 - During spring and fall months, chilled water to be supplied by a centrifugal chiller located in the building. Both chilled water and condenser water pumping systems shall have backup units. Size chiller and chilled water lines for total building loads.
- “Reheat” systems must be evaluated carefully to determine if they are the most economical for temperature and humidity control.
- Primary heating for the building to be from one or more high-efficiency condensing hot water boilers in the building. Heating systems to be designed as variable flow primary with complete redundancy if possible providing full capacity to the building in case of equipment failure. Steam via a transmission system from the central heating/steam plant could also be used for backup heating in some designs.
- Owner training provided by the equipment manufacturer or the manufacturers’ local trained representative must be included with every project. Training must include a visit to the site, overview of available resources on the equipment and where to find them, explanation of sequence of operations, and allotted time for questions from University staff.
- Design systems for full 100% economizer mode when applicable.

Domestic water

- Domestic water heaters to be gas fired instantaneous (preferred), gas fired condensing models, OR heat exchanger systems connected to building heating boilers. The type of system depends on the specifics of each project and the resources available in the building (natural gas and heating water).
- Storage tanks should not be used unless necessary, and designs should be as efficient as possible.

Equipment

- Building chiller to be fitted with “Marine Water Boxes” on both chilled water and condenser water connections. High pressure chillers are preferred.
- Building boilers to be high-efficiency condensing type __ brand with stainless steel construction. Cast iron boilers are NOT acceptable.
- Provide standby pumps for chilled water, condenser water, and hot water systems. Close-coupled pumps are not to be installed on chilled water systems.
- Air Handling Units to be as approved by UM.
- Condensate return systems shall have duplex pumps and motors.
- Cooling accomplished by variable air volume (VAV) pressure independent systems.
- Refrigerant as approved by University representatives.

Roof Top Units

- Brands to be as approved, either gas heat or heat pump.
- For ventilation package units, make-up air package units, and 100% outside air units the approved brands are [AAON](#), [MUNTERS](#), and [VALENT](#).

Mechanical Insulation

- Cover all exposed insulated lines with an aluminum jacket and proper labeling.
- All piping, tanks, valves, and other heat producing or heat absorbing (Chilled Water Pumps) equipment shall be insulated and covered with an aluminum jacket.
- Insulate all mechanical room ceilings.
- All insulated piping shall bear “NO ASBESTOS” warning labels.
- All ductwork shall be externally lined.

HVAC Controls, Building Automation, and Instrumentation

- All HVAC systems to be monitored and controlled by the University “Building Automation System” (BAS). Include all necessary field hardware, and related computer software in all Construction Contracts. The goal is for every building to have a single brand, uniform, control system with access to the entire building from one front end. If a project will replace only a portion of the building controls, the spec will call for the new controls to match any existing controls that meet

University standards. Any approved vendor may submit a bid, but if they do not have any existing controls in the building they will need to replace ALL existing along with the new project controls to keep the system consistent.

- All communicating DDC devices - controllers (supervisory, programmable, configurable, etc.) to be from one of the three approved expanding vendor systems: TRANE *Tracer*, JOHNSON CONTROLS *Metasys*, or DISTECH “*EC-NET*” (designed with NiagaraAX). No other brands will be accepted. They must be listed by the BACnet Testing Laboratories (BTL).
- Supervisory controllers must have a web-based interface, and allow for a “pass-through” software function to service the unit level controllers.
- All communicating field devices (including meters and controllers for power, water, and lighting and other building systems) to use the BACnet open protocol and be listed by the BACnet Testing Laboratories (BTL). They must transmit across a local MS/TP bus (EIA-485), or use BACnet/IP across the campus LAN. Packaged equipment and drives (for example chillers and boilers) should be ordered with a BACnet communication option (if available), but may be integrated *directly* to a capable supervisory controller using their own protocol if BACnet is not available (for example Modbus or LonTalk). A third party gateway should only be used if these other options do not exist. LonTalk field devices should not be used except in special cases, to be approved individually.
- Every new HVAC project or renovation that includes controls should include; 1) Connection to and communication with one of the three expanding BAS front ends (Tracer ES, Metasys ADX, and Niagara AX by Distech), 2) A full graphics package including 3D floor plans, 3) Control schematic As-Builts (laminated sheets) for the equipment and the controllers placed in the controls enclosures, electronic copies of the As-Builts, and electronic backup copies of all the controller configurations and programs throughout the control system (unit level and supervisory).
- All control system enclosures (panels with BAS equipment/devices) must be equipped with a subpanel or “perf” panel, disconnect switch or breaker, convenience outlet, and hardwired BAS Ethernet switch (if LAN connected equipment is present).
- All VAV boxes or terminal units must include a discharge air (leaving air) temperature sensor in addition to the standard points and devices.
- All control valve and damper actuators (and any actuator that is NOT physically integrated into a terminal unit controller) must use a proportional (analog) control signal OR communicate directly on the BACnet comm bus. No “floating” or “tri-state” actuators are permitted. All 24vac actuators must carry a minimum 5 year manufacturer’s warranty.
- All rooms and/or spaces to have individual room temperature control capability and space temperature sensors located with customer’s controls (at the same level)—sensors located in the return air are not to be used as space temperature control sensors.
- No new pneumatic control devices are permitted on any project.

- At completion of any retrofit/upgrade including new controls, all old control equipment (devices, controllers, wiring, etc.) that will not be immediately reused must be demolished and removed completely. Some control enclosures and conduits may be emptied and left (with approval) for future use.
- All thermostats and related controls to be DDC. All rooms and/or spaces to have individual DDC room temperature control, provided by DDC sensors.
- Air compressor unit to have dual compressors and sized to operate 1/3 on, 2/3 off.
- All NEW equipment to have a sealed laminate/plastic schematic drawing mounted on the nearest partition and labeled.

Actuators and Operators

- All actuators and/or operators for chill water shall be 120vac with compensation heaters for moisture control. All other actuators and operators can be 24vac.
- Electric controls shall be used only in the mechanical room for unit heaters, hydronic, electric, or natural gas.

Sensors and Transmitters

- Each and every space where there are offices, work space, and classrooms shall have individual control. Sensors and thermostats may be, but not limited to, wired or wireless depending upon circumstance, construction materials and associated costs.

Control Valves

- All chilled water and hot water control valves up to 6 inch to be ball valves with stainless steel ball and trim, equal percentage flow characteristics, and minimum close-off pressure of 100 psi.
- All chilled water and hot water valves 6 inch and larger to be butterfly valves with ductile iron full lug body, stainless steel disc and shaft, and EPDM seat. Butterfly valves shall be rated for a minimum of 100 psid close-off pressure (50 psid for undercut valves). Butterfly control valves to be equipped with 120vac industrial actuators with NEMA 4 enclosure with position indicator (visual), internal overload protection, internal heaters (for CHW applications), electronic position feedback (switches, analog signal, or direct communication), and an external manual override mechanism. All 120vac industrial actuators must carry a minimum 2 year manufacturer's warranty.
- Any modulating valves to be equipped with proportional actuators only. No "floating" or "tri-state" actuators are permitted. All actuators to be 24vac for valves up to 2 inch and may be 120vac for larger valves. Only one actuator per valve is permitted; no "stacked" actuators or "dual" actuator configurations on any valve, regardless of size.
- All steam control valves to be ball valves rated for use with steam (up to 15 psi), temperatures up to 250 deg F, with stainless steel ball and trim, and equal percentage flow characteristics.

- All chill water control valves on air handlers, incoming feed valves for variable primary pump scheme, shall be the modified sphere construction and be ball valves 8 inches and less and if used at higher diameters shall be concentric - off set seated butterfly style, lug type valve.
- The only part of the large control valves shall come with 120 vac electric motors. Compensation electric heaters shall be used on air handler chill water valves. The control circuit shall be electronic floating point circuitry with feedback.

Control Dampers

- Control dampers, depending on use, can be from seal tight for balancing.

Energy management system - TRANE, JOHNSON CONTROLS or Distech. No Substitutions.

- All direct digital control systems shall be either stand alone or capable of connecting to the energy management system. The system can be factory or unit mounted and the pricing of the unit mounted controls shall include the labor to install. All conduit required for low or high voltage shall have compression fittings, not screwed type fasteners. The ends of conduit shall have wire protection on the open ends.

Electric and Electronic Control System for HVAC

- ONLY controls that can be addressed in some manner shall be accepted.

Pneumatic Control System for HVAC

- NO pneumatic control system shall be used on campus unless there is a justified exception and approved by the University.
- Pneumatic damper operators controlled by DDC are acceptable.

Pneumatic and Electric Control System for HVAC

- No combination of Pneumatic and/or electric controls shall be used on campus unless there is a justified exception and approved by the University.

Sequence of Operations for HVAC Controls

- The chill water sequence shall be variable primary pumping, with two- way valving on all end devices.
- The chillers, if incorporated, shall control their own components and be given an enable signal from the central EMS system. The chillers and cooling towers shall be capable of max capping strategy for optimum energy savings. The primary scheme for all chiller plant operation is Primary Variable Flow.
- Hot water hydronic heating systems shall be primary variable flow configuration.

- Air handlers on the air side shall be controlled by VAV using critical zone reset for maximum energy savings and reduced horsepower of the motors.
- The use of powered VAV boxes shall be allowed ONLY by direct written approval of the University.
- The employment of variable refrigerant flow concept that is currently being used in various buildings shall be a predominant factor when low amounts of outside air is required and can incorporate the use of energy recovery devices and can incorporate a diversity up to 150 percent. Large amounts of fresh air requiring separate make-up air units shall incorporate the latest technology such as inverter compressor with infinite stepping TXV, oil recovery and the use of R-410a refrigerants. The make-up air unit shall incorporate the use of energy recovery wheels and the use of Uv emitters and electro static filtration included is a pre-filter that is in a V-configuration.
- In the sequence of operation of air handlers large and small there shall be a reference for full economizing cycle. This includes package or dual fuel units.
- There shall be a sequence of operation for fresh air monitoring and documentation. All drain pans shall be IAQ Stainless Steel construction. No puddle larger than a quarter shall be left in pan after shutdown.
- The chiller room shall be under the control of the chiller sequence for the start and stop of cooling tower fans, no bypasses, pump start and stop. Chiller shall control its own destiny and receive an enable signal.
- VAV Boxes shall be stand alone, capable of connection to an energy management system and must control the temperature of space. It shall monitor discharge air temp., reheat temp., and, since reheat can be hydronic or electric, monitor the status of each. Hydronically the two way valve shall be opened for 10 seconds to determine if hot water is available. Each VAV box shall be capable of programming, monitoring from the thermostat.

HVAC Piping and Pumps

- ** Do NOT use galvanized piping; abandon and remove where possible. All domestic water piping shall be copper. Do NOT use solder containing lead.

Hydronic Piping

- Underground steam piping shall be engineered and shall be equal to in all aspects to Thermacor. Thrust blocks that are part of the system shall be rounded and not squared off. No sharp edges shall be felt. It shall be painted with a corrosion inhibitor then shrink wrapped at the factory. Each wall penetrating end shall have a steel band as it enters and leaves a wall so that the mechanical

seal will not crush the jacket. All specifications shall be strictly adhered. This includes owner and manufacture verification and sign off on all hydronic testing and first inspection of the insulation of the joint process. All piping shall be tested at one and half times the operating pressure which is 95 pounds of steam. All underground piping shall be free of any debris and must be verified and certified by the contractor on the job. All underground projects shall be stamped, engineered projects; no sticks and pieces shall be allowed on any underground project.

- All underground hydronic piping for **chill water** shall be engineered with the University approving the shop drawings, verification of pressure testing, and factory approved methods of joint insulating. No stick or non-engineered piping shall be approved without specific University approval. If non-engineered piping is installed without University approval it shall be subject to removal at contractor expense.

Above ground Hydronic Piping

- NO above hydronic piping is approved on the University Campus

In-Line Centrifugal Hydronic Pumps

- When mounted or suspended all pumps shall be supported on both sides. There shall be room for motor removal.
- All pumps shall be flanged and come with an extra set of seals delivered to the University representative. The seal kits shall fit the application of the pump, hot water or chill water. This shall be indicated on the parts box.

Base-Mounted, Centrifugal Hydronic Pumps

- All base mounted pumps shall include volute support and not be supported by the piping. NO EXCEPTIONS.
- Extra seal kits with the pump application indicated.

Vertical-Mounted, Double-Suction Centrifugal Hydronic Pumps

- All pumps shall be provided with a means to hoist components and move to transport convenience.
- All vertical mounted pumps shall come with a means of motor removal. The removal of the motor shall include self-alignment of the coupling and the removal and replacement of seals without the removal of pump.
- The pump shall come with extra seal kits for application and the training required for maintenance.

Automatic Condensate Pump Units

- All condensate pump sets shall come with pre-wired starter and alternating sequencer.

- All condensate steam pump units shall come with the control package mounted on the tank shell. This to include the alternator motor starters, disconnect, and heater resets. There shall be extra seal kits for each pump. All sets shall be duplex unless used for make-up to a low pressure steam boiler.

Steam and Condensate Piping and Pumps

- Recommended manufacturer is THERMACOR.

Steam and Condensate Heating Piping

- The systems installed on Campus using underground systems have been very successful when installed according to Manufacturer's Specifications.
- The trench shall be dug according to the drawings attached to the CSI Standard for Underground piping. The University understands there will be points when depth and distance between pipes must change. This can only happen with the consent of the University. All changes in elevation must be approved and new shop drawing sent with the Manufacturer's approval along with a finished engineered copy with signatures from the University and Designer. No sticks and pieces allowed on any engineered project as they void the warranty.
- There shall be training by the manufacture's factory representative for the contractor's employees and the University shall see and verify the training.
- No more than a 2 degree deviation from center is allowed for change of direction to get around an obstacle. This has to be approved by the University and Manufacture's representative.
- All pressure tests, training on material movement, factory training on installation of insulation shall be verified by both the manufacturer's representative and University Representative and shall become part of the construction documents.
- There shall be no 45° joints.
- All engineered piping shall be tagged for assembly.
- All pieces entering a wall where link seals shall be used for moisture containment shall come with a metal jacket over the insulation and sealed to the carrier pipe. The metal jacket keeps the insulation from being crushed and deforming the insulation.
- All insulation for steam carrier piping shall be capable of no less than 345° of steam at 95psig.
- The condensate insulation shall be designed for no less than 250 degrees and for use as pumped condensate. The condensate carrier pipe shall be schedule 80 and schedule 80 fittings shall be used if it meets the Manufacture specifications.

- The thrust plate shall be treated with a corrosive resistant material and shrink wrapped against the acids that are in concrete. This shall be done at the factory. The thrust plate shall be rounded and not square. There shall be a detail on the plans showing the procedure.
- Two different steam carrier systems shall not be combined or attached to each other unless the action is taken in a pit situation where the two enter the walls and are connected inside the pits through various methods.
- All shop drawings must go through a procedure for approvals that include the manufacturer's engineer, Designer of record and Owner's representative.
- All condensate valves used for condensate delivery shall have carbon steel bodies rated at 2000psig. Packing shall be rated for steam. All piping in pits shall be schedule 80 included fittings.
- All below grade steam carrier ball valves shall be stainless steel ball and trim, full-ported, stainless steel bodies. This is good through and including 8 inches diameter.
- All chill water piping used below grade and in areas (crawl spaces) shall be pre-insulated and follow the manufacturers' specifications for training, pressure testing as below grade steam pipe.
- Most important that all changes in field installation due to elevation or change of direction must go through the Designer of record, Manufacturer and Owner and it must be signed off by all.

Underground Steam and Condensate Heating Piping

- All underground steam piping shall be engineered and shall be equal to in all aspects to THERMOCOR. System thrust blocks shall be rounded and not squared off. It shall be painted with a corrosion inhibitor the shrink wrapped at the factory. Each end that penetrates a wall shall have a steel band as it enters and leaves a wall so the mechanical seal will not crush the insulating jacket. The steam condensate line shall always be schedule 80 piping and meets the same standards as the carrier piping. All high pressure trapping must go thru a flash tank system before it goes into the low pressure pumped condensate system. This system can be mounted in a building or available pit. The insulation shall be appropriate for 345 degrees. All projects shall be stamped and engineered. No sticks and pieces shall be allowed on any University Project.
- All below grade direct burial piping shall be Schedule 80 engineered insulated piping from structure to structure.
- Fittings shall be Schedule 80 welded or threaded.
- Piping in a pit or building may be stick Schedule 80.
- All valves shall be rated body and reinforce packing. See valves.
- The drawing below shows High pressure Condensate to Low pressure condensate.

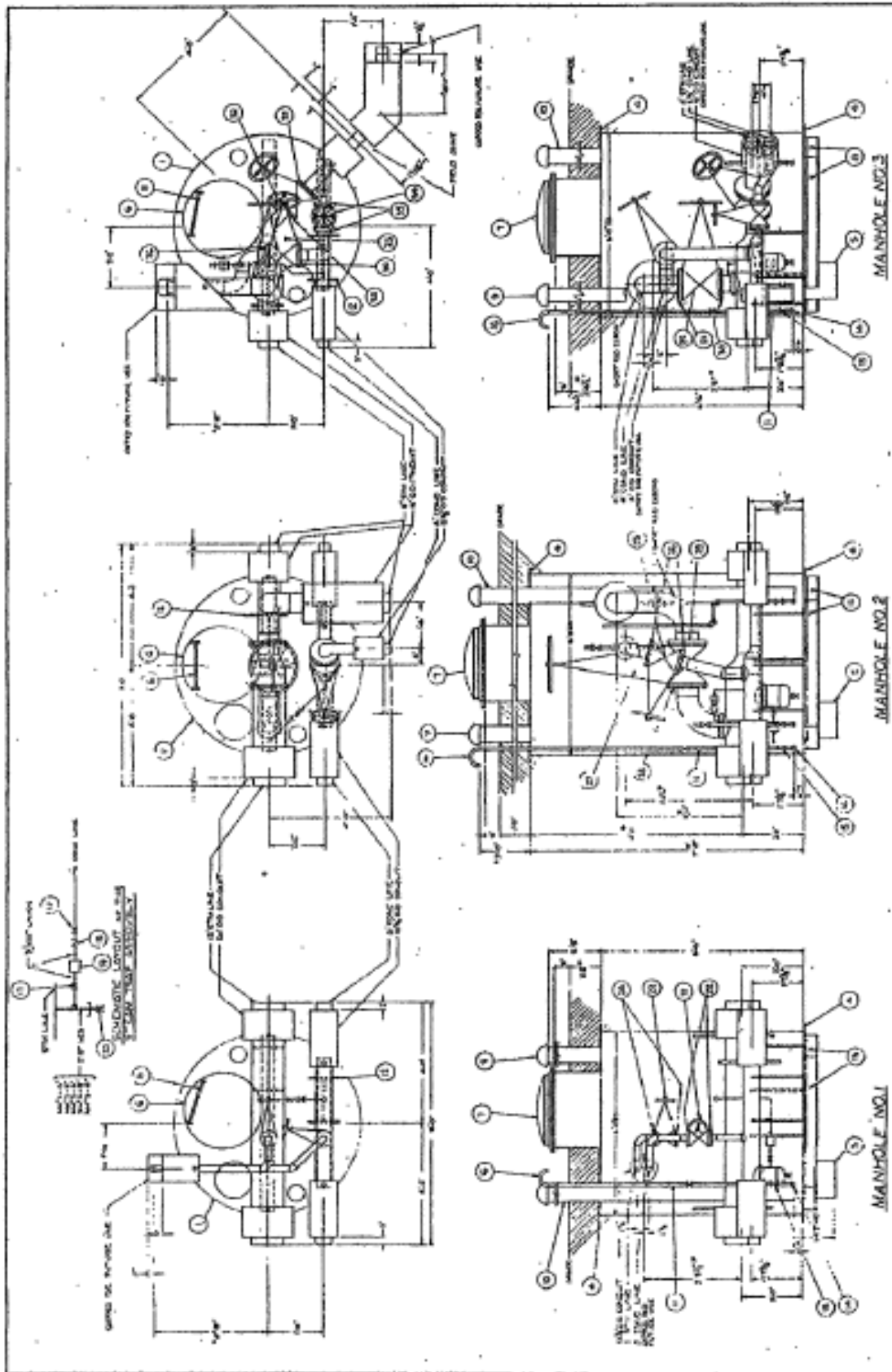

REVISIONS		DATE		BY		CHECKED		APPROVED	

PROJECT NO. _____
 SHEET NO. _____ OF _____
 DRAWN BY _____
 CHECKED BY _____
 APPROVED BY _____
 DATE _____

TYPICAL SUBMITTAL OF MANHOLES FOR UNDERGROUND DISTRIBUTION SYSTEM
 PROJECT NO. _____
 SHEET NO. _____ OF _____
 DRAWN BY _____
 CHECKED BY _____
 APPROVED BY _____
 DATE _____

NO.	DESCRIPTION	QUANTITY	REMARKS
1	MANHOLE NO. 4	1	
2	MANHOLE NO. 5	1	
3
4
5
6
7
8
9
10
11
12
13
14
15
16
17
18
19
20
21
22
23
24
25
26
27
28
29
30
31
32
33
34
35
36
37
38
39
40
41
42
43
44
45
46
47
48
49
50

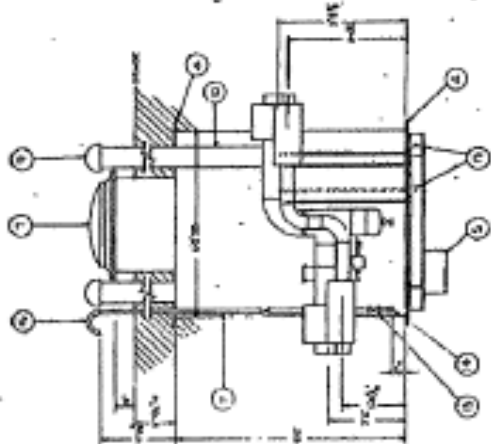
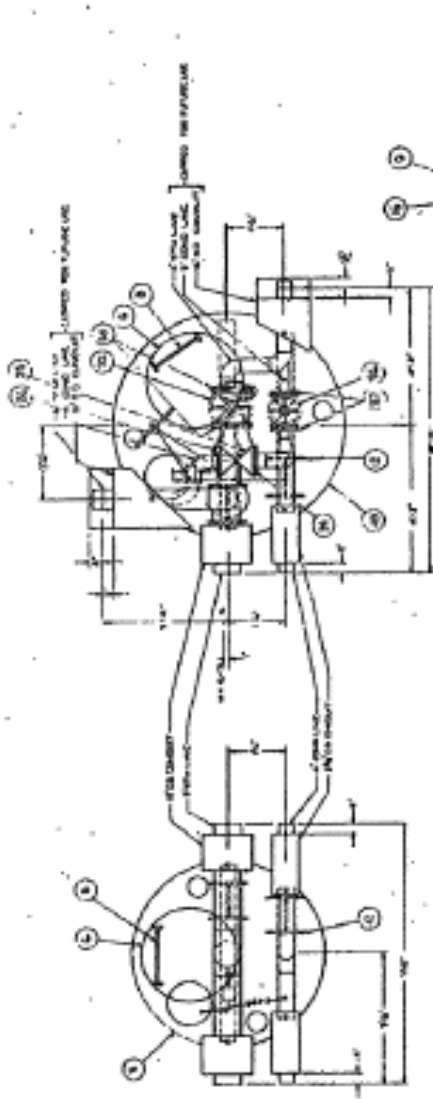

MANHOLE NO. 4

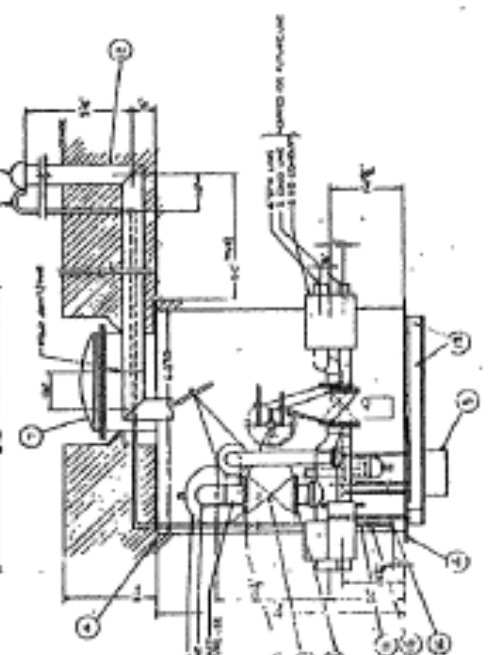
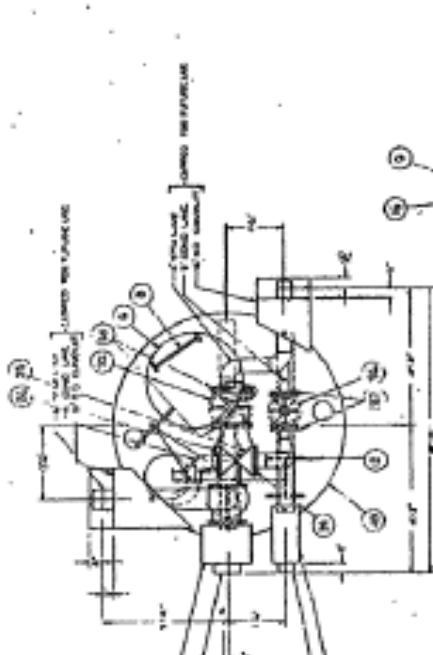

MANHOLE NO. 5

1. MANHOLE NO. 4 AND NO. 5 ARE TO BE CONSTRUCTED IN ACCORDANCE WITH THE FOLLOWING SPECIFICATIONS:
2. THE MANHOLE SHALL BE CONSTRUCTED OF CONCRETE AND SHALL BE 4' IN DIAMETER.
3. THE MANHOLE SHALL BE 4' DEEP AND SHALL BE 4' IN DIAMETER.
4. THE MANHOLE SHALL BE 4' IN DIAMETER AND SHALL BE 4' IN DIAMETER.
5. THE MANHOLE SHALL BE 4' IN DIAMETER AND SHALL BE 4' IN DIAMETER.
6. THE MANHOLE SHALL BE 4' IN DIAMETER AND SHALL BE 4' IN DIAMETER.
7. THE MANHOLE SHALL BE 4' IN DIAMETER AND SHALL BE 4' IN DIAMETER.
8. THE MANHOLE SHALL BE 4' IN DIAMETER AND SHALL BE 4' IN DIAMETER.
9. THE MANHOLE SHALL BE 4' IN DIAMETER AND SHALL BE 4' IN DIAMETER.
10. THE MANHOLE SHALL BE 4' IN DIAMETER AND SHALL BE 4' IN DIAMETER.

UNDERGROUND DISTRIBUTION SYSTEM

MANHOLE NO. 4

MANHOLE NO. 5

MANHOLE NO. 6

MANHOLE NO. 7

MANHOLE NO. 8

MANHOLE NO. 9

MANHOLE NO. 10

MANHOLE NO. 11

MANHOLE NO. 12

MANHOLE NO. 13

MANHOLE NO. 14

MANHOLE NO. 15

MANHOLE NO. 16

MANHOLE NO. 17

MANHOLE NO. 18

MANHOLE NO. 19

MANHOLE NO. 20

MANHOLE NO. 21

MANHOLE NO. 22

MANHOLE NO. 23

MANHOLE NO. 24

MANHOLE NO. 25

MANHOLE NO. 26

MANHOLE NO. 27

MANHOLE NO. 28

MANHOLE NO. 29

MANHOLE NO. 30

MANHOLE NO. 31

MANHOLE NO. 32

MANHOLE NO. 33

MANHOLE NO. 34

MANHOLE NO. 35

MANHOLE NO. 36

MANHOLE NO. 37

MANHOLE NO. 38

MANHOLE NO. 39

MANHOLE NO. 40

MANHOLE NO. 41

MANHOLE NO. 42

MANHOLE NO. 43

MANHOLE NO. 44

MANHOLE NO. 45

MANHOLE NO. 46

MANHOLE NO. 47

MANHOLE NO. 48

MANHOLE NO. 49

MANHOLE NO. 50

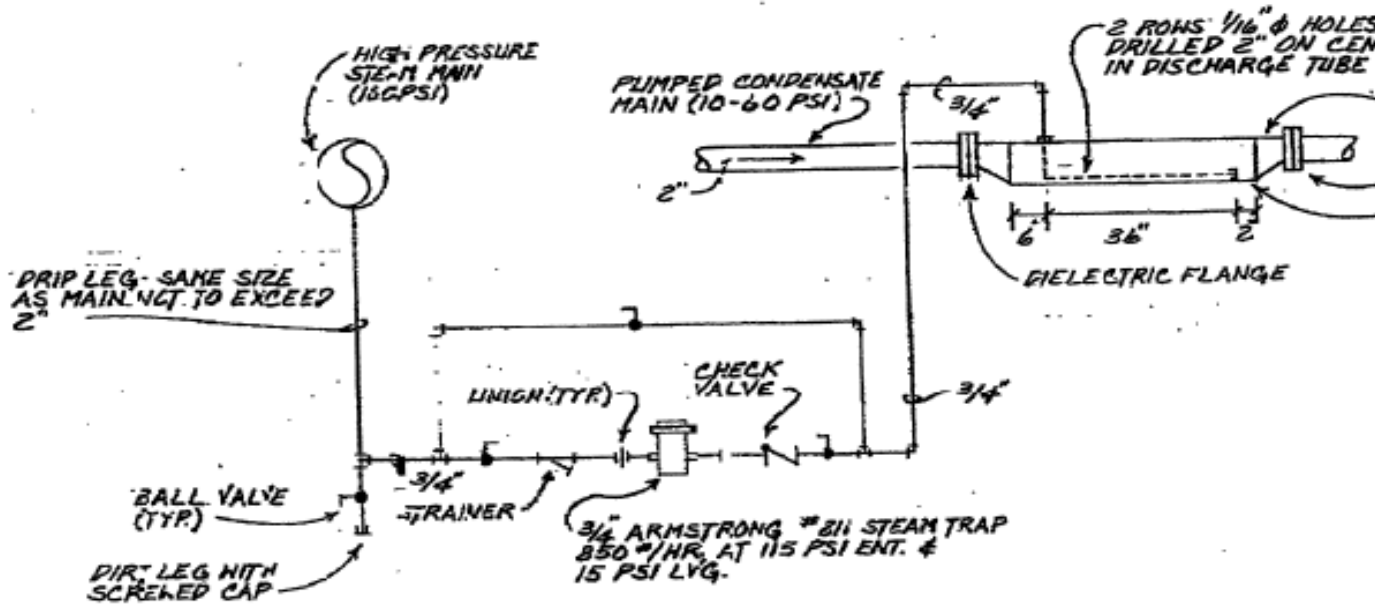

HIGH PRESSURE STEAM LINE
 DRIP STATION N MANHOLE
 NO SCALE

1/3/92

Pos-It brand fax transmittal memo 751		* of pages *	
To: BIL SINGLETERY	From: Gordon Nye/3		
On: Physical Plant - MSU	By: B. S. C. B.		
Dept:	Phone: 52-6223		
Fax: 578-4888	Fax: 48-9440		

STEAM AT ENTRANCE
 1 EXISTING PERMA-PIPE STEAM PIPING CONDUIT.

- The above drawing shall be a part of all underground systems.
 - Above-ground Steam and Condensate Heating Piping
- After the piping enters the building, the piping can be stick and insulated. The condensate return shall be schedule 80 pipe and fittings. The insulation shall be appropriate for the temperature of 345°. The insulation shall be jacked up to 7 feet above grade.
- Above ground only in Mechanical Rooms. All condensate piping, and fittings, shall be Schedule 80. Valves shall have a minimum of 2000 psi rated carbon steel body with reinforce packing. See valves.

Electric-Driven Steam Condensate Pumps

- All motors shall have electrical protection in the form of a starter sized for the motor specified. There shall be an alternator to provide equal use of the motors on a duplex system.

Refrigerant Safety Relief Valve Discharge Piping

- Shall be piped so as to provide vibration isolation and to the highest point of the building.

Refrigerants

- The use of blends shall be restricted and have to be preapproved by the University

HVAC Water Treatment

- The University has a water treatment contract and it should state for the contractor to contact the University contact person for information. All water treatment shall include the vendor that has the existing water treatment for the University as a whole.

HVAC Air Distribution

- Fabricate and support in accordance with SMACNA “Low Pressure Duct Construction Standards” and ASHRAE handbook and approved methods of rating assembly requirements of designated agencies. Use existing ductwork, make modifications as required. Provide new extensions to match existing ductwork as needed.

HVAC Ducts and Casings

- Metal Ducts
- Rectangular Metal Ducts – preferred, internally lined only
- Round and Flat-Oval Spiral Ducts - Any and all air distribution devices used on spiral duct shall be gasketed and part of a system.
- Metal Duct Fittings - Hard fittings shall be used on any and all changes of air flow direction.

Non-metal Ducts

- Concrete OR Fibrous-Glass Ducts - Not allowed on Campus
- Thermoset Fiberglass-Reinforced Plastic Ducts - Flex duct can only be used in the vertical plane and cannot change direction with a hard fitting.

HVAC Casings

- Acoustical Air Plenums - Any and all acoustical air Plenums must be pre-approved by the University
- Air Duct Accessories
- *Pneumatic tubing* - Type to match existing provided by the University. All pneumatic lines to be hard-drawn copper tubing.
- *Condensate drains* - 1-1/2” ID Schedule 40 PVC pipe, all fittings shall be DWV. L copper shall be used long runs and runs that are in a fire rated area. The copper drain line is the preferred material in areas where there is excess heat buildup and steam is present or neat by. All condensate lines shall be insulated.

- Install components in strict accordance with manufacturer's installation instructions and approved submittals.

Dampers

- Fire Dampers
- Interlocking blade fire damper, curtain type. Minimum fire resistance rating to be 1 1/2 hour. Fabricate and install components according to manufacturers' installation instructions, approved submittals, the requirements of UL-555 and NFPA 90A, and approved methods of rating assembly requirements of designated agencies.
- Fire Dampers & doors:
- Backdraft Dampers
- Wall cap – [BROAN 642](#) - 4" round duct aluminum wall cap with built-in back draft damper.
- Wall Vent cap – [BROAN 639](#) (stock # 2C090) 3-1/4" x 10" duct with spring-loaded damper, flange 12-3/4" x 5-5/8" weather-tight seal, paint to match brick.
- Turning Vanes - Turning vanes shall be installed, even if the duct is semi round.

Access Doors

- Ductwork access doors - Fabricate and support in accordance with SMACNA "High Pressure Duct Construction Standards", ASHRAE handbook and approved methods of rating assembly requirements of designated agencies. All door access to duct work and/or walls shall have UL approved labeling and testing.

Flexible Connectors

- All connectors shall be manufactured and NO LOCAL fabrication shall be allowed.

Flexible Ducts

- Flexible Duct – HART & COOLEY 6" and 8" diameter Class 1 air duct metalized jacket. Max. Length is 3 feet in the vertical plane only.
- Flexible Duct – DURA FLEX XL1888 silver foil back. Max length is 3 feet vertically only.
- Hard Insulated Elbow – Any and all changes of direction require a hard duct fitting.
- Flex duct can ONLY be run vertically, cannot change directions and the length shall not exceed 36 inches. No flex duct shall be used on any inlets to the high pressure side of VAV boxes. Or any boxes that are used as such. No horizontal use of flex duct shall be accepted.
- Fabricate and support in accordance with SMACNA "*Low Pressure Duct Construction Standards*" and ASHRAE handbook and approved methods of rating assembly requirements of designated

agencies. Use existing ductwork, make modifications as required. Provide new extensions to match existing as needed.

Duct Liners

- Duct liner shall not be used on any return duct work unless expressly said so and a written exception is given. Case in point, transitional returns for acoustical purposes.
- All duct work shall be externally insulated. Duct liner can be used for noise reduction at individual space return above ceiling. This must be used in conjunction with short elbow.
- Any use of duct liner must have University prior approval.

HVAC Fans

- Axial HVAC Fans – not allowed

Centrifugal HVAC Fans

- Centrifugal inline duct fan – KANALFLAKT INC. K4, 4" diameter inlet / outlet, 122 CFM.
- All fans used on air handlers shall be as an assembly and vibration isolated. Assembly includes motor mounts, fan housing, bearings, shaft pulleys, and blower wheel.

HVAC Power Ventilators

- Ceiling ventilating fan - GRAINGER / DAYTON 2D065 with molded white easy-to-clean snap-in grille, galvanized steel housing with integral back-draft damper, 163 CFM at 0.125" SP.
- Ceiling ventilating fan - BROAN, type to match building standard.
- All Ventilators shall be ECM Motors direct drive and be speed adjustable either mechanically or electrically.
- All roof mounted ventilators shall sit on a curb with a minimum of 18 inches above roof grade.
- All electrical whips shall be mounted to a curb mounted rated box as to water proof the inside conduit from the outside conduit

Bath exhaust

- Sawdust Collection Systems - They shall be treated as a hazard and potential fire hazard.
- Engine Exhaust Systems
- Positive-Pressure Engine Exhaust Systems
- Mechanical Engine Exhaust Systems
- Air Terminal Units:

- Constant-Air-Volume Units
- Each unit shall come w/air flow metering device, reheat option mounted.
- Each unit shall come w/air temperature sensor and ddc controls.
- Units can come with factory OR unit mounted ddc controls. If unit mounted; the labor to mount the controls shall be part of the controls package and shall be clearly noted.

Variable-Air-Volume Units

- VAV Boxes – TRANE # VDDE2424 variable air volume double duct control terminal units, size 24 heating air valve, 24 cooling air valve, ½” matt faced insulation, field supplied flange connection (Fld), direct digital controls without remote heat, Ddc sensor, external adjuster, night set back, communication jack (Fld), 120/24 volt transformer, control disconnect switch, control line fuse
- VAV Box – TRANE # VCWE11, MANNING 10" variable air volume single duct terminal unit with: Size 11 heating air valve, ½” matt faced insulation, Flanged outlet connection, Shutoff with hot water heat, High capacity hot water coil, Left hand coil connection, 120/24 volt transformer, Control disconnect switch, Control line fuse, Direct digital controls with proportional hot water valve control, and 1 - Ddc sensor, external adjuster, night set back, communication jack (Fld) Part # X1351060602, and 1 - 1.8Cv (1.55Kv) ddc prop hot water valve (Fld) Part # X13680411020. *Note: Trane's "Everywhere Software" is needed for test and balance. (Fld) indicates furnished by Trane, installed by others.*
- Any other Vav boxes specified shall include a control box that is no larger than the VAV box itself. Any box larger rustics the ability of the contractor to install the vav box close to the deck due to the control box being to large for the intended purpose. *Case in point is Downtown Law School.*
- Each unit shall come w/air flow metering device; reheat option mounted along with an air temperature sensor and ddc controller, with fused disconnect and hot water valve two way.
- This factory mounting of all controls
- If the controls for the vav box are unit mounted there still has to be the same control configuration and the labor costs must be included.

Air Outlets and Inlets

- All ceiling diffusers, grilles and registers shall come with factory mounted insulation. No work in the field shall be accepted. Install all components according to manufacturer's installation instructions and approved submittals. After completion of the project - before owner acceptance - test and balance all ductwork and grille modifications / additions according to recommendations of the

Associated Air Balance Council. Test quantities must be within 5% of the quantities specified. Submit a formal report to the University for review and comments.

Return air grilles

- HART & COOLEY 2' x 2' PDR perforated diffuser, Dover white enamel finish. **No Substitution.**

Supply diffusers

- HART & COOLEY 2' x 2' PDSD perforated diffuser supply with deflectors, *3800 series* butterfly damper with removable handle, *5400 series* snap in collar (as required), Dover white enamel finish. Or equal. Must have factory insulated backs no exception.

Fabric Air Distribution Devices

- The fabric Air distribution devices shall be of slot style at a 22 - 45 degree with the material allowing for air to bleed through all 360 degrees. The material must come with a 10 year warranty and capable of being cleaned using normal noncommercial washing methods. The material shall also be capable of decoration as to sell advertisement if so desired.

HVAC Gravity Up blast Ventilators

- All rotating parts shall be out of air stream and be capable of at least 20 foot plumes. All controls, actuators shall be capable of movement greater than a delta P5 inches of water column or greater. All hoods shall be tested according to ASHRAE Standards
- Ventilation Hoods – as approved
- Commercial-Kitchen Hoods – as approved
- Fume Hoods – as approved

HVAC Air Cleaning Devices

- Particulate Air Filtration – as approved
- Panel Air Filters - The filters must be rated at a MERV 8 or greater.
- Washable Air Filters - Shall be of the type that can be vacuumed or washed and have an everlasting biocide to kill mold and mildew. They shall be from the equipment manufacturer to not allow for air leakage around the media.
- Extended Surface Filters - All computer room equipment shall no less than a MERV 11. All other air handling equipment shall be 2 inch MERV 8. All air handling equipment shall come with electrostatic filtration with UV lighting on the coils. The electrostatic shall be capable of .3 micron particulate or less. And the electrostatic shall not produce ozone.

- High-Efficiency Particulate Filtration
- Ultra-Low Penetration Filtration - They shall be used as secondary filtration with ultra-low static pressure drop and can be electrostatic with no ozone.
- Activated-Carbon Air Filtration - For use in electrostatic filtration by the use of impregnation of filter media
- Chemically-Impregnated Adsorption Air Filtration - No off gasing allowed on any filtration product
- Electronic Air Cleaners (Washable, Agglomerator, Self-Contained) – as long as there is no off gasing and no ozone produced.
- Electronic Filter Air Cleaner – HONEYWELL 15000 Enviracaire, 600 CFM.

Central Heating Equipment

- Breechings, Chimneys, and Stacks - All stacks and gas flue designs shall go to the existing chimney system and shall not go to the exterior of a building
- *Wall vent cap* – BROAN 639 (stock # 2C090) 3-1/4" x 10" duct with spring-loaded damper, flange 12-3/4" x 5-5/8" weathertight seal, paint to match brick.
- Fabricated Breechings and Accessories
- Fabricated Stacks - according to manufacturer's specifications.
- Condensing Boilers – Shall be 5 to 1 turn down ratios or better efficiencies shall be 95 percent or greater.
- Stainless-Steel Condensing Boilers - Due to the corrosives in the condensing water at the base of flue and in the boiler itself that 316 Stainless steel modified for this purpose. Shall be 5 to 1 turn down ratios or better and shall have efficiencies 95 percent or greater.
- Aluminum Condensing Boilers – not recommended for this application due to the corrosive nature of the condensing water PH
- Pulse Combustion Boilers – Use in a boiler room separate from an occupied space due to noise and possible vibration. These boilers are good for building heating systems but not for domestic water heating.
- Cast-Iron Boilers - Cast iron boilers are not acceptable.
- Water-Tube Boilers –
- Finned Water-Tube Boilers – Due to problems inherit to this style it is not used on Campus

- Heating Boiler Feedwater Equipment and Deaerators - The pump section shall be a duplex system with alternating control system. Pump alarms for failed pump and low water cut off for the boiler and tank system
- Electric -Resistance Furnaces – not allowed
- Gas-Fired Furnaces
- All gas fired furnaces shall be a min. of 95% AFLUE. The primary and secondary heat exchanger shall be stainless steel.
- All gas pack style furnaces shall be a min. of 90% efficient with stainless steel heat exchangers

Heat Exchangers for HVAC

- Steam-to-Steam Heat Exchangers - Use Stainless Steel tubing for improved life and reliability
- Steam-to-Water Heat Exchangers - Use Stainless Steel tubing for improved life and reliability
- Liquid-to-Liquid Heat Exchangers - Depending on the two liquids as to use of stainless steel
- Plate-Type, Liquid-to-Liquid Heat Exchangers
- Shell-Type, Liquid-to-Liquid Heat Exchangers
- Direct Geexchange Heat Exchangers

Central Cooling Equipment

- Refrigerant Compressors – (Centrifugal, Reciprocating, Scroll, or Rotary-Screw)
- Packaged Compressor and Condenser Units - (Packaged Air-Cooled & Packaged Water-Cooled)
- Refrigerant Condensers - All water cooled condensers shall have marine water boxes on one end of the machine.
- Packaged Water Chillers - The evaporator shall be separate and located inside a mechanical room. No water component shall be outside.

Central HVAC Equipment

- Thermal Storage – (Thermal Heat, Chilled-Water, or Ice Storage)
- Air-to-Air Energy Recovery Equipment – (Heat-Wheel, Heat-Pipe, Fixed-Plate, Packaged Units)
- All air handlers shall come with an access section between hot water and chill water coils.
- It shall be noted the drain pans shall be arranged to have no more than quarter size of puddled water standing. All drain pans shall be 304 stainless steel and shall be broke to eliminate any puddling of water.

- All air handlers shall come with a central location for all sensors and actuators and controls for mixing box can be wired.
- All fan sections shall be vibration isolated and bearing support shall be aligned for the greatest bearing support.
- All air handlers shall have full economizers and the mixing boxes shall be factory made.
- Modular Indoor Central-Station Air Handling Units - The modular stations shall include a controls package that uses the air handler for a bases of operation. All VAV boxes and associated equipment shall be report and be controlled by air handler and/or its components. The air shall have the vav's report to the controller to determine occupancy by CO2 monitoring and also by schedule. The Modular air handler shall consist of double wall construction with corner posts insulated as well. The fan section shall be on vibration isolation within all construction with corner the air handler. There shall be an Stainless Steel IAQ pan both under the chill and hot water coils and both shall be piped to the drain. The controls shall be factory or unit mounted. The supplier shall provide the field mounting, start up, commissioning of each point and the technical training for maintenance personnel. All air handlers shall come with ultraviolet emitters facing the coil and drain pan. The filtration shall be electrostatic with activated carbon impregnation. The electrostatic filters shall not emit any ozone. There shall be access between sections.

Indoor Central Station Air Handler – Example TRANE # MCCA008 with the following:

- Modular Base Unit – unit size 08, standard split with 4” to 6” base rail mounting legs, UL listed insulation shall be foam no less than R-13. Supports shall be no sweat and all access doors and hardware shall not sweat. Solid double wall.
- Factory Controls Package – VFD with bypass; PCM 20 point; unit mounted drive side; space sensors with timed override/SP (Fld); outside air sensor (Fld). All controls and sensors shall be wired to a central point
- Air Mixing Module (Pos. # 1) – mixing box with filters; access door; top and back dampers with parallel blades; 2” pleated media unit filters; electronic actuator; averaging temperature sensor.
- Blank Module (Pos. # 2) shall contain access door.
- Vertical Coil Module (Pos. # 3) – stainless steel drain pan; entering air freezestat; electronic 2-way control valve – normally open, water (Fld); chill water shall be no less than a 16 degree deltaT.6 row cooling coil enhanced copper tubes.
- Vertical Fan Module (Pos. # 4) – access door; fan discharge @ top and back; open drip proof high efficient E- motor; ½” rubber-in-shear isolation; 3 hp, 460/60/3 voltage; fan discharge temperature sensor; air flow switch; starter – NEMA 1 enclosed – indoor.

- Deluxe beige finish. Install according to manufacturer's installation instructions and approved submittals. *Note: Trane's "Everywhere Software" is needed for test and balance. (Fld) indicates furnished by Trane, installed by others.*
- Custom Indoor Central-Station Air-Handling Units - The modular stations shall include a controls package that uses the air handler for a bases of operation. All VAV boxes and associated equipment shall be report and be controlled by air handler and/or its components. The air shall have the vav's report to the controller to determine occupancy by CO2 monitoring and also by schedule. The Modular air handler shall consist of double wall construction with corner posts insulated as well. The fan section shall be on vibration isolation within all construction with corner the air handler. There shall be an Stainless Steel IAQ pan both under the chill and hot water coils and both shall be piped to the drain. The controls shall be factory or unit mounted. The supplier shall provide the field mounting, start up, commissioning of each point and the technical training for maintenance personnel. All air handlers shall come with ultraviolet emitters facing the coil and drain pan. The filtration shall be electrostatic with activated carbon impregnation. The electrostatic filters shall not emit any ozone. There shall be access between sections.

Packaged Outdoor HVAC Equipment

- All packaged outdoor equipment shall have the utilities come up thru the equipment and/or roof curb.
- All roof top equipment shall have a roof curb of no less than 18 inches tall.
- All packaged HVAC equipment shall have the same height (18 inches) and have built-in vibration elimination.

Packaged, Outdoor, Central-Station Air-Handling Units

Package shall meet the same requirements as Indoor Central air handlers. The piping schemes shall be part of enclosure to keep units from freezing. The piping shall either enter from under the unit or be enclosed. The rest of utilities shall come under the unit as feasible.

Decentralized HVAC Equipment

- HVAC Unit – LIEBERT *Mini-Mate Plus*, DMC037A condensing unit and MME036E above dropped ceiling evaporator unit, 3 ton split-type, cooling capacity of 32,100 BTU/HR, reheat coils 22,100 BTH/HR, 2 speed circulating air fan for dehumidification control, 208V, 1Ph, 60 Hz., direct-drive fan with self-aligning sleeve bearings and lifetime lubrication, finned tubular electric reheat with safety switch. Each system capable of 1250 CFM at .3 inches of water external static pressure. Control to have 2 humidity set points for humidification and dehumidification functions with a minimum 4% RH differential and automatically switch from humidifying to dehumidifying based on return air

conditions. Humidity control set point range to be 20% - 80% RH. LIEBERT wall mounted microprocessor control, LCD display with 8 key membrane keypad, programmable on a daily basis or 5 day / 2 day schedule, accepting 2 programs per day. Control to activate an audible & visual alarm following field conditions when temperature maxes 90F, min 35F and humidity Max 85%, Min 15% RH. Pre-charged refrigerant lines sets: Type as recommended by manufacturer. Seamless copper tube water line, hard drawn, type L, ASTM B88. Full port bronze body stainless steel ball valves, unless otherwise noted.

- HVAC Unit – LIEBERT Data Mate DMC037A condensing units and DME037E evaporator units, wall-mounted.
- HVAC Unit – JANITROL GUPS120-5 vertical, UC-60 evaporator coils, re-pipe as required. Condenser CE60-F. Thermostats - Pneumatic thermostat provided by the University and installed by the Contractor.
- HVAC unit – JANITROL 60MAQ-4 horizontal ceiling hung, 120 volts with 60,000 Btu/hr cooling coil and a separate hot water coil, refrigerant lines and control wire. Condenser *CE60-3*, 200/230 volt, Thermostat – HONEYWELL *T87F* with Q839 sub base.

Room Air Conditioners

- Air conditioner – WHITE WESTINGHOUSE *WAL125P1A*, 12,000 Btu, 115 volt, 9.0 EER, through window unit.

Computer Room Air Conditioners

- Computer Room units shall comply with IAQ with stainless steel drain pans, electronic control of humidity and temperature of the space. The CPU shall have the capability of monitoring compressor functions, input power, shall have the capability of monitoring compressor functions, input power, chill water coil and chill water temperature to allow the system to work at the most economical manner. It shall have the ability through open protocol and Web browsing to provide the information necessary of all functions that the unit is monitoring. Any refrigerant circuit shall be separate from the other. Each unit shall come under floor water detection.

Split - System Air Conditioners

- The system shall be 16 SEER or better if it is found economically feasible above 16 SEER. The drain pans shall be of IAQ quality and shall come with UV emitters on the coil section. Uv emitters shall be part of any spec sent out by an engineer for any of the units that may be specified. Electrostatic filtration shall be used where there are students, faculty and staff.

Air - Source Unitary Heat Pumps

- Air conditioner / heat pump - GE Zonline PTAC/PTHP, one fan motor and microprocessor controls, 14,100 / 13,800 Btu, 208 / 230V. Provide with wall case and exterior grille; color as selected.
- Air conditioner / heat pump - GE Zonline AZ51H15DAC, 5100 series, two fan motor and microprocessor controls, 14,100 / 13,800 Btu, 208 / 230V. Provide with wall case #RAB70, exterior grille # RAG66 and all necessary components, color as selected.
- Fan Coil Air Conditioner - TRANE UniTrane # FCBB1201KK0A0G1(LH) & # FCBB1201JK0A0G1 (RH); vertical cabinets, size 120, 115v/60hz/1ph, with piping, front toe space return, top quad grille supply, free discharge fan motor, 3 row cooling/1 row heating coil, 144 fins/ft, manual air vent, disconnect switch, 1" throwaway pleated media filter (Farr 30/30), 3 way modulating Cv =1.5 (50 psig) cooling and heating control valves, deluxe ball valves (supply and return) with Autoflow valve, TUC (Terminal Unit Controller) DDC controls, unit-mounted zone sensor module, OALMH fan mode switch and setpoint dial, 9.0 gpm main and 1.0 gpm auxiliary Autoflow valves, deluxe beige finish. Install according to manufacturer's installation instructions and approved submittals.
- Convactor – INTERNATIONAL ENVIRONMENTAL FHY06, 2 pipe HW/CW fan coil unit with wall mounted control, 2-way motorized valve and auto C/O Aqua-Stat.
- Convactor - TRANE 300 CFM unit, vertical cabinet with baked enamel finish, left hand controls, thermostat, non-corrosive, positively sloped, easily removable drain pan, motor/fan 120V, single phase, 100 watts. Options include factory-installed interconnecting piping package, three-way two position control valves, inlet and outlet style toe space and quad grille; color as selected.

Humidity Control Equipment

- Humidifiers - Humidifiers shall be ddc controlled and the use of a separate system to generate a finer mist is required. Stainless steel pans are a requirement for units using infra-red light.
- Dehumidifiers - Dehumidifiers must come with a way for reheat unless the load in the space is sufficient.

Outdoor Airflow Control

- When the air handler is providing mechanical cooling control the outdoor air ventilation damper in order to deliver proper outdoor airflow to the VAV system at all load conditions. Outdoor airflow to be sensed by an airflow measuring station (using thermal dispersion technology) at the outdoor air intake and maintained at the calculated minimum outdoor airflow set point determined by ASHRAE Standard 62-89, Equation 6.1. Recalculate the correct minimum outdoor airflow set point every 30 minutes (operator adjustable). The ATC system shall solve Equation 6.1 dynamically for all connected VAV spaces to determine minimum outdoor airflow set point required to properly ventilate all VAV spaces at all operating conditions. Recalculate the set point periodically (every

30 minutes, operator adjustable) based on prevailing VAV space conditions. For each VAV space, the ATC system shall compare actual measured space airflow at each VAV terminal to the required ventilation airflow as scheduled. The ATC system shall determine the critical space ventilation fraction from the VAV zones and the total supply airflow; then use Equation 6.1 to determine the correct minimum outdoor airflow set point, adjusting for the recirculation credit allowed by the Equation to reduce energy usage.

- When air handler is providing economizer cooling determine outdoor airflow by supply air temperature requirements. Compare actual outdoor airflow to calculated minimum outdoor airflow set point to ensure flow is higher than minimum outdoor airflow set point; *then*, based on the actual outdoor airflow, the system shall periodically use Equation 6.1 to determine maximum allowable critical space ventilation fraction.
- Alternatively, a demand-based control scheme may be used (instead of ventilating to a minimum occupied volume) incorporating CO2 sensors, IAQ sensors, and/or occupancy sensors in each controlled zone, communicating the need for ventilation back to the supervisory control system and the AHU controller. Each zone will control independently to one global air quality set point for the building.
- System to graphically display critical ventilation VAV space location, system supply airflow, ventilation fraction, calculated minimum airflow set point, and actual measured outdoor airflow.

Cooling Towers

- Stainless Steel only

Variable Refrigerant Flow Systems (VRF and VRV)

- VRF systems (of all kinds) must be from one of the three approved vendors for the campus; MITSUBISHI ELECTRIC, DAIKIN AC, and SANYO. Only used for computer room or elevator room systems.

VFD on AHUs, Fans, and Pumps

- Variable (Adjustable) Frequency AC Drives (VFDs) mounted alone or with packaged equipment must have inverters from one of the following approved vendors: DANFOSS, ABB, TRANE, or YORK. The bypass section (required when the equipment is capable of running across the line) must incorporate a third contactor or a disconnect switch to isolate the inverter for service.
- All fans and pumps (including cooling towers) that are not single speed to be equipped with VFDs.

Operation and Maintenance of Facility Fuel Systems

- All fuel lines and tanks shall be cleaned and dried by nitrogen before fuel is added.
- All alarms and status lights shall be operational at time of installation.
- All lines shall be pressure tested and data recorded and given to the Owner.

- Test boilers on oil to be sure the pressure drops are maintained and correct for the application.

Operation and Maintenance of HVAC Piping and Pumps

- All lines shall be pressure tested to one and half time the operating discharge pressure of the pump.
- Pumps: All pumps shall be field aligned and free of any undue pressure due to pipe weight or orientation. Pumps shall be aligned according to manufacturers' specification and report(s) turned into the Owners representative. If pump comes with an inertia frame base, the inner section shall be filled with grout after installation.
- Pump assembly shall come as a complete unit with self-supported volute. The motor shall be mounted and aligned to the pump assembly. Inspect and align per manufacturers specifications.
- The motor shall be connected to the electrical system by no more than 3' of flex conduit.
- Piping: No PVC shall be used in a rated room or near hot water and steam systems. This includes drain systems for any and all mechanical equipment.
- Copper: Only "K or L" copper shall be used on water side of air handling equipment.
- Refrigeration: Only copper designated for refrigeration shall be used and must come sealed and have a nitrogen charge.

Operation and Maintenance of HVAC Air Distribution

- No flex duct shall be allowed on any high pressure inputs to VAV boxes. Three (3') feet will be allowed on low pressure side, vertical plane only, but cannot change direction.
- All 24" x 24" ceiling diffusers shall come with factory mounted insulation to the backs of each diffuser.
- All side-mount, bar type grilles shall come with opposing blade dampers for balancing purposes.

HVAC Air Duct Cleaning

- All duct work shall be clean of all dust and debris before installation.
- All duct work and accessories shall be kept in a clean, dry environment before installation.

Operation and Maintenance of Central Cooling Equipment

- All operational and maintenance training and operation shall be the responsibility of the contractor.
- Chillers shall have a 16° (degree) Delta T across the evaporator.
- Chillers shall control all components that are directly related to the chiller operation, including the cooling tower, bypass, valve operation condenser water pumps. The central ems system shall

enable the chiller and provide for chill water temperature reset as determined by algorithm...
Chillers shall operate in the max cap region for energy savings when conditions warrant.

- Refrigerant Recovery / Recycling
- It is the Owners' responsibility to recover and recycle any and all refrigerants and oils and dispose of as and according to EPA regulations in the Clean Air Act.

Common Motor Requirements for HVAC Equipment

- All motors shall be service factor of no less than 1; preference would be 1.5,
- All large horsepower motors shall be dual voltage.
- All fan coil motors shall be PSC, **not** shaded pole, unless it is the only thing available and there must be a written exception presented to owner.
- All motors where available shall be the ECM type for efficiency and reliability.

Expansion Fittings and Loops for HVAC Piping

- All piping, fittings and loops shall be engineered; NO exceptions.
- All underground thrust block plates shall be round and no pointed edges with corrosive inhibited coating and be shrink-wrapped from the factory.
- All ends shall have a metal jacket to prevent the ends from crushing due to link seal installation.
- All piping end pieces shall be finished a minimum of 6" from the end of insulation.

Meters and Gages for HVAC Piping

- All end devices shall have visual gages and meters installed.
- All meters and gages inside a mechanical room shall be visible / readable with no obstructions from the floor.
- All meters and gages shall be in a brass or stainless steel well filled with a heat transfer compound.

General - Duty Valves for HVAC Piping

- Use threaded full ported, bronze body ball valves with a stainless steel ball and trim, in a nylon or Teflon seat. NO SUBSTITUTION unless dictated by code. Soldered valves NOT acceptable.
- Provide full port ball isolation valves for each restroom and stops for each fixture.
- Install reduced pressure backflow preventers per code at 7' maximum above finished floor.

- Use sleeves and link seals, rated per code, at vertical penetrations of mechanical and plumbing piping.
- No globe or gate valves shall be allowed on any project
- No triple duty valves shall be allowed on any project.
- All general ball valves can be brass or carbon steel bodies. The minimum rating is 600psi and all shall be pipe threaded. No sweat ball valves shall be allowed.
- All general ball valves 4 inches and above shall have a gear operator. All mounted 7 feet or higher shall have a chain gear operator.
- Ball valves shall be used on all piping 8 inches and below. Butterfly valves shall be used on all piping 10 inches and above. They shall be the concentric shut-off with built in gaskets. This is the only time Butterfly valves may be used.

Specialty Valves by Need

- **Steam Duty:** All valves below grade shall be stainless steel ball and trim and body and can be rebuilt. The packing shall be reinforced and capable of 345° and up to 250 pounds of pressure. Steam trap valves 2 and 1/2 pipe size or smaller shall be stainless steel ball and trim reinforced packing and rated at 2000 pounds with carbon steel bodies or stainless steel bodies used below grade.
- **Chill water:** All chill water valves used on air handlers shall come with a modified stainless steel sphere and trim capable of low flow water with minimal pipe noise to shut off. (Control valve). Two way only Cv sized. Fan coil units: control valve shall be capable of shut off with a delta p. of over 50 psig. Two way only size for the Cv of device and cannot be sized smaller than two pipe sizes of coil.
- **Hot water:** All hot water control valves shall use same sizing as chill water control valves and characteristics
- **Low pressure steam valves:** These valves shall have the same characteristics as the chill water but must be rated to handle steam pressure and the packing must be able to handle the pressure They must use reinforced packing

Hangers and Supports for HVAC Piping and Equipment

- Support mechanical equipment according to the SMACNA “*Low Pressure Duct Construction Standards*”, ASHRAE handbook and approved methods of rating assembly requirements of designated agencies.

- Obtain approval from University Representative for all partition or ceiling attachments to be made for any device, fixture, or equipment; *especially* in exposed, open areas. Existing attachment points or holes must be properly repaired to accept new finish to match surrounding finish.

Heat Tracing for HVAC Piping

- All make-up water piping that is outside a building envelope shall have heat trace installed and an alarm shall be sent to the EMS system should the heat trace fail.
- All cooling towers, and any other outside unit having make-up water or no potable chill water, shall be heat traced and include an alarm picked up by the Energy Management System. Alarm is to indicate that no current is being drawn through the heat trace system after activation by Energy Management System.

Identification for HVAC Piping and Equipment

- Signage shall include direction of flow, chill water or hot water, potable and non-potable. The equipment shall be numbered. The Electrical side shall indicate the breaker panel from which power originates.

Anti-Microbial Coatings for HVAC Ducts and Equipment

- The use is a favorable option for new installations. Use in conjunction with UV emitters for HVAC duct work on old installations.

Anti-Microbial Ultraviolet Emitters for HVAC Ducts and Equipment

- All emitters shall emit C band Ultraviolet and use a standard base; Phillips or equal.
- All ultraviolet emitters shall have band width indications as to what diseases it will kill and the time required in the light path to be effective.

Testing, Adjusting, and Balancing for HVAC

- Install components according to manufacturer's installation instructions and approved submittals. After completion of the project - before owner acceptance - test and balance all ductwork and grille modifications / additions according to recommendations of the Associated Air Balance Council. Test quantities must be within 5% of the quantities specified. Submit a formal report to the University for review and comments. The test and balance company shall be AABC certified no others shall be accepted.
- Only companies associated with AABC shall be accepted for the adjusting and balance of water side and air side of HVAC.

HVAC Insulation

- All piping, tanks, valves, and other heat producing or heat absorbing (Chilled Water Pumps) equipment shall be insulated and covered with an aluminum jacket.
- Insulate all mechanical room ceilings.

Duct Insulation

- Return duct insulation - interior insulation shall be used only on L-shape noise elimination transfer duct. EXCEL 2lb. FHC/25-50/-1/2 or equal. All other return duct work shall be externally wrapped with the same insulation as the supply duct work.
- Supply duct Insulation – OWENS CORNING Fiberglas all-service faced duct wrap insulation, 2" thick or equal.
- All duct work shall be insulated exterior of the duct on both the low pressure and high pressure side of VAV boxes. All exceptions to this rule must be approved by the University. All ductwork shall be externally lined. External wrapped duct work that is exposed shall have a smooth coating applied. The material determined by the use of space.
- Noise reduction elbows can be internally lined with a duct liner certified not to be an agent for mold and mildew growth.
- All VAV boxes shall come with a true vapor barrier (aluminum / scribe)

Equipment Insulation

- All equipment shall be double wall construction (large air handlers). Small devices shall come with a vapor barrier on all insulation that meets the air stream.
- The R factor shall be not less than R-13 and all support post, panels, and access doors. All drain pans shall be insulated and shall be free from the threat of condensation.
- All air handlers shall be of double wall construction with or without anti-microbial coatings. The air handler must physically fit the assigned space and provide adequate room for other accessories that are assigned to the air handler first.

Piping Insulation

- Piping insulation – ARMSTRONG 1 1/2" Fiberglas (NOT Armaflex).
- All vertical runs up to 7 feet shall be jacketed.
- All drain lines from chill water coils and pans shall be insulated with no less than 1/2" ARMAFLEX insulation.

- ALL Hot water piping shall be insulated a minimum of 1” formed fiber glass with vapor barrier. All fittings to be full to the thickness of the existing insulation. The covering shall match the thickness and be PVC.
- Chill water piping shall be insulated a minimum of 1-½” of formed fiber glass. All fittings shall be full to the thickness of the existing insulation. The covering shall match the thickness and be PVC.
- Closed cell insulation on refrigerant lines shall be no less than ½” thickness and joints shall be air tight. Closed cell insulation is good on all valves and accessories that cannot have fiber glass insulation on it. All voids shall be full. Closed cell insulation is NOT to be used on high temperature piping.
- All insulated piping shall bear “NO ASBESTOS” warning labels
- Cover all exposed insulated lines with an aluminum jacket and proper labeling.
- Install all components in strict accordance with manufacturer’s installation instructions.

Commissioning of HVAC

- The commissioning agent shall be under state contract and shall be a part of design, control automation, and all aspects mechanical installation.

Plumbing:

General Design Requirements

- Retrofit all existing plumbing (faucets, showerheads, piping, etc.) to meet present codes.
- Evaluate facilities for large gatherings of people (auditoriums or stadiums) for the number of toilet fixtures needed based on anticipated usage rather than minimum code requirements.
- Utilize automatic flush systems on all water closets and urinals.
- Provide a hydrant on roofs of buildings.
- ALL bathroom installations – new and renovations - shall have a floor drain.

Catch basins

1. Dimensions shown are minimum, depending on estimated water flow.
2. Catch basins shall be vented.
3. Commercial laundry catch basins shall have a removable wire basket or similar device that will prevent clothing debris or other material from entering the drainage system.
4. Basket shall prevent solids 1/2" or larger from entering the system.
5. Check valve shall be installed in the outlet of the basin.
6. Cleanout shall be installed in the outlet as per the diagram.
7. Covers of catch basins must remain clear for servicing, with no bulky equipment installed so as to block accessibility.
8. Rim and cover must be of the pattern of Memphis Machine Works Pattern #1002, made of cast iron.

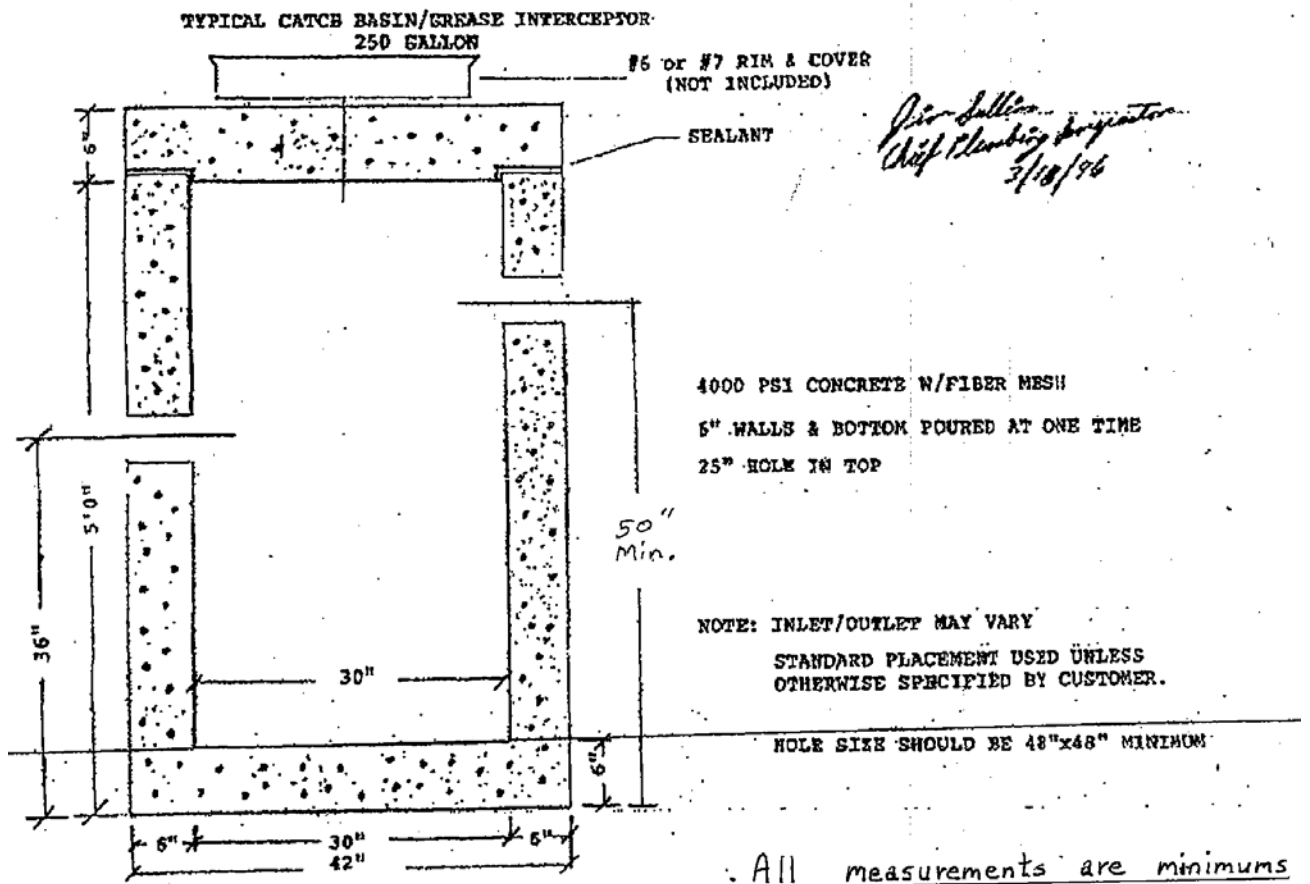

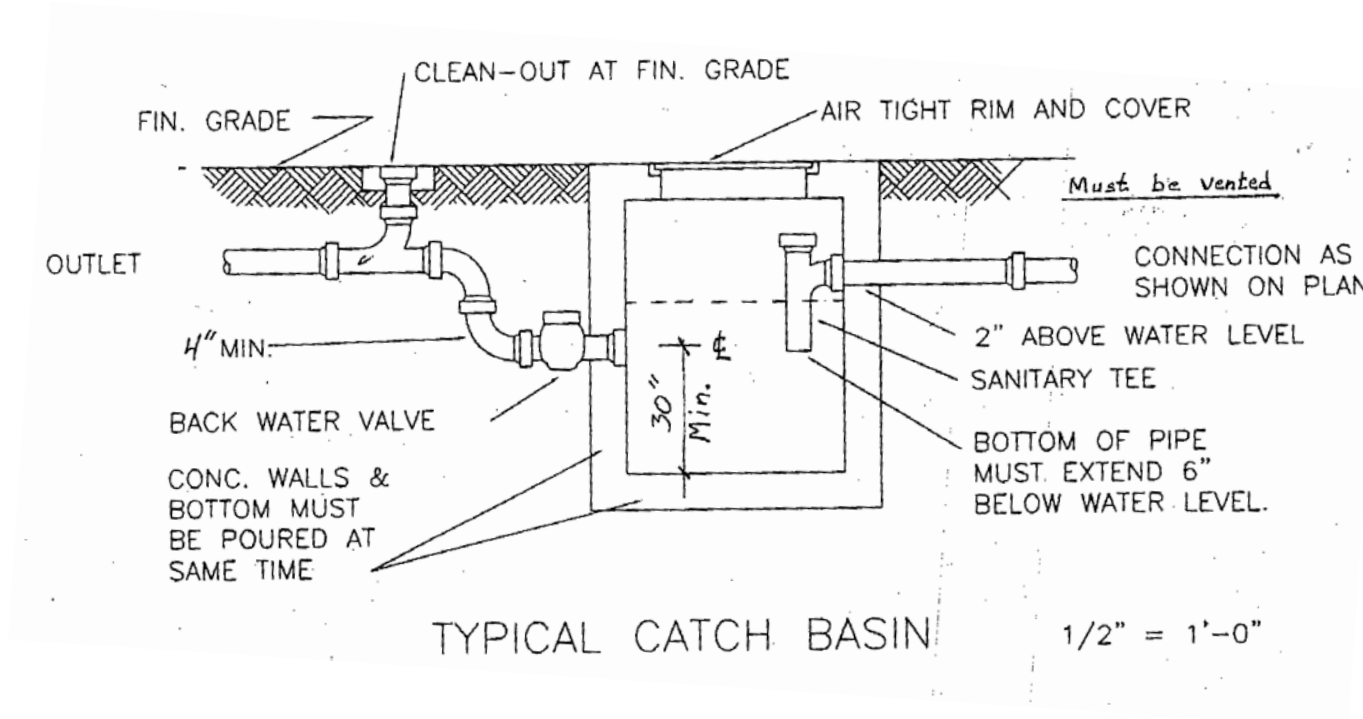

Fire Protection

- Install an automatic fire sprinkler system in all new and renovated facilities unless specifically approved otherwise by the University.
- Fire alarm system and clock system to be SIMPLEX.

• Diagram and sketch (below)

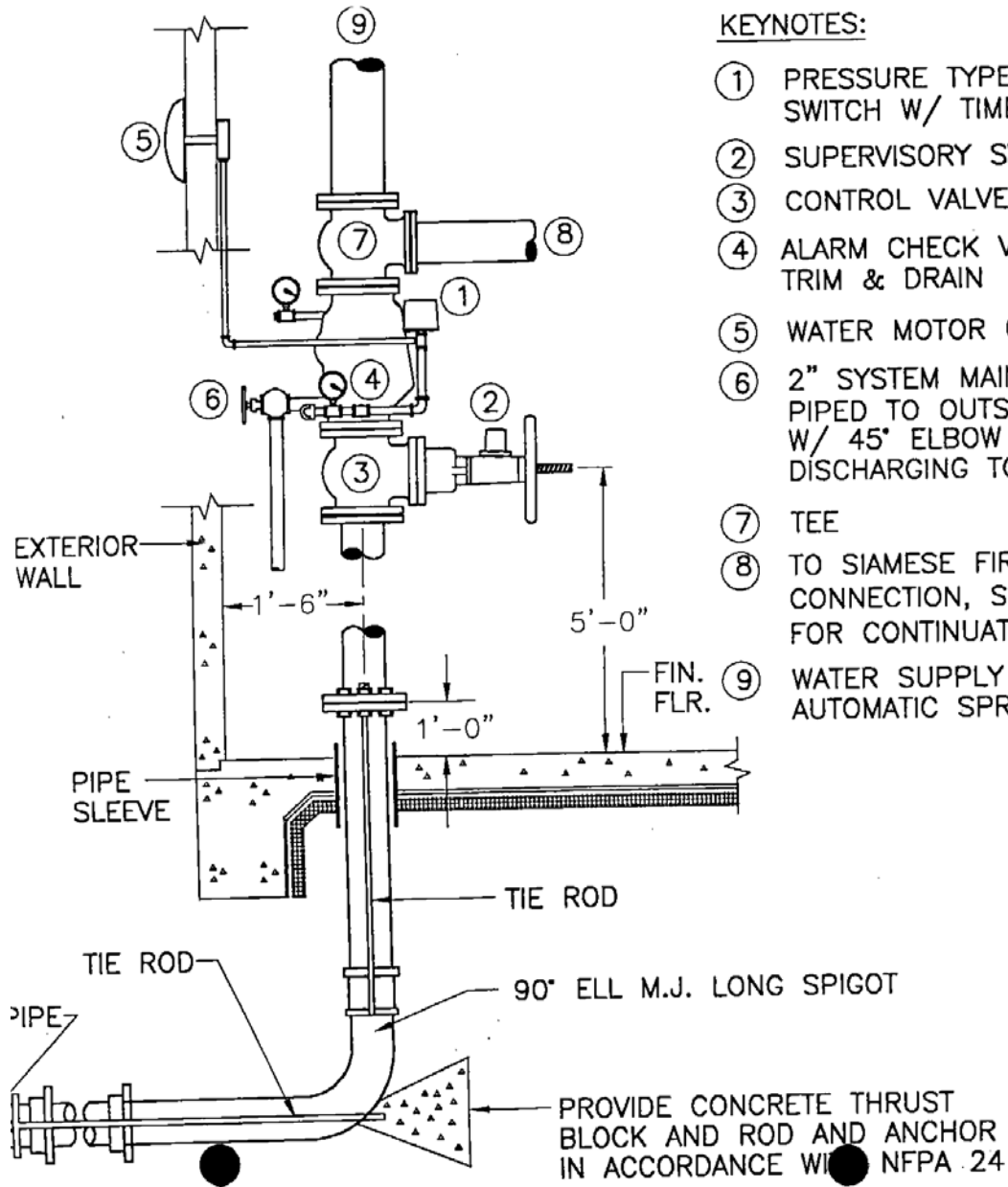

KEYNOTES:

- ① PRESSURE TYPE WATERFLOW SWITCH W/ TIME DELAY
- ② SUPERVISORY SWITCH
- ③ CONTROL VALVE
- ④ ALARM CHECK VALVE WITH TRIM & DRAIN
- ⑤ WATER MOTOR GONG
- ⑥ 2" SYSTEM MAIN DRAIN VALVE PIPED TO OUTSIDE TERMINATING W/ 45° ELBOW AT GROUND LEVEL DISCHARGING TO SPLASHBLOCK.
- ⑦ TEE
- ⑧ TO SIAMESE FIRE DEPARTMENT CONNECTION, SEE SHEET P1.8 FOR CONTINUATION.
- ⑨ WATER SUPPLY PIPE TO AUTOMATIC SPRINKLER SYSTEM.

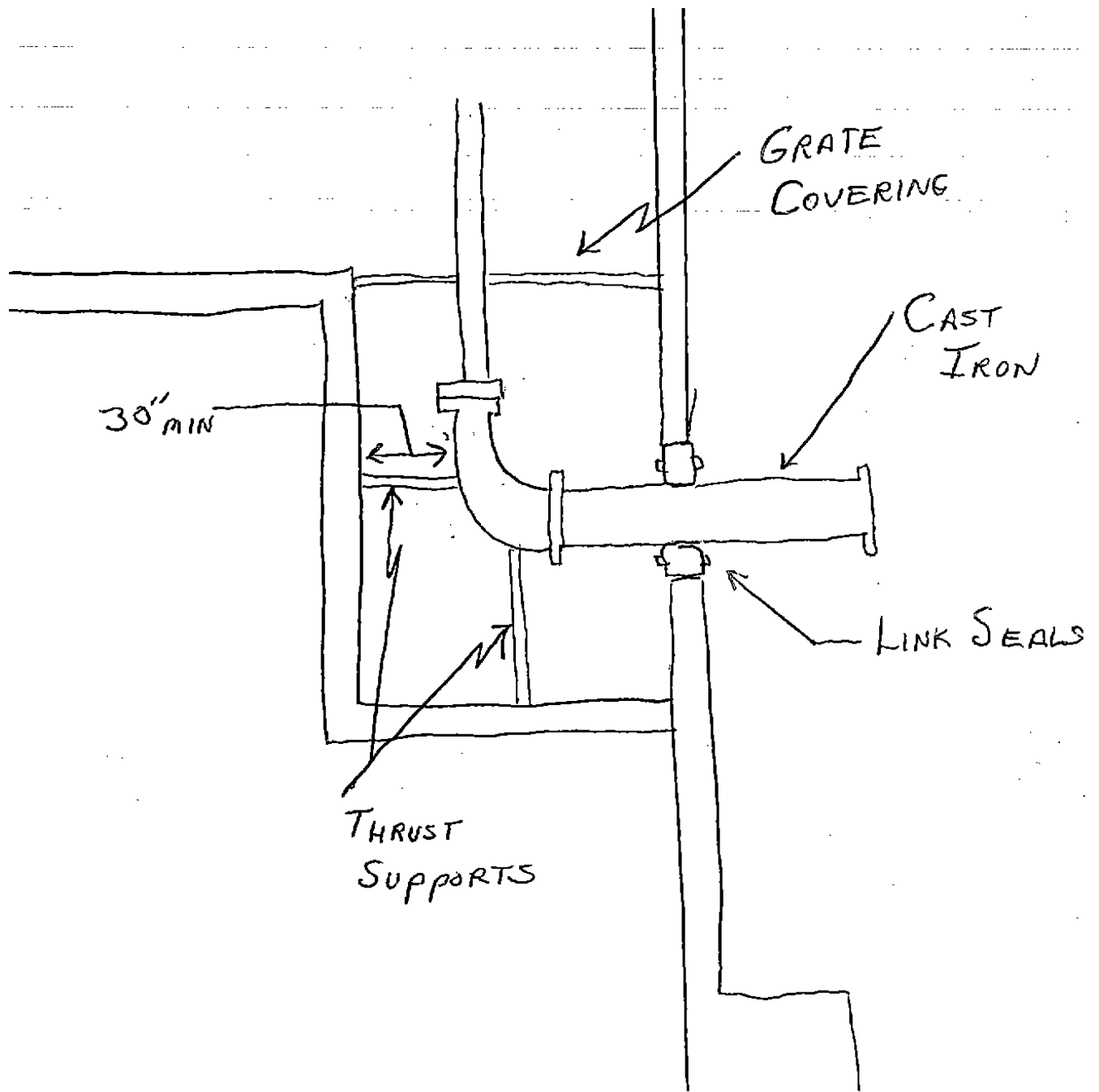

FIRE PROTECTION WATER ENTRANCE

Manholes

1. Manholes shall be of concrete and may be either precast or poured in place.
2. They must present a smooth surface in the interior.
3. If precast, joints must be sealed either by a rubber ring or by applying a wet cement mixture.
4. Floors shall be poured concrete with shaped channels for proper flow of liquids.
5. If rungs are required, they must be cast in place, not drilled and added at a later time. Rungs shall be equal to Memphis Machine Works Pattern 2000.
6. Top sections must be eccentric, rather than concentric so that rungs will be directly above each other, rather than offset. See diagram.
7. Rim and cover shall be of the Memphis Machine Works Pattern 1002, cast iron, minimum size and weight.
 - A. Cover for sanitary sewer shall be marked "SEWER."
 - B. Cover for storm drain shall be marked "DRAIN."
 - C. Owners may require heavier rim and cover for unusual conditions.
8. At completion of installation, cover shall be level with surrounding area or no more than 1" high.

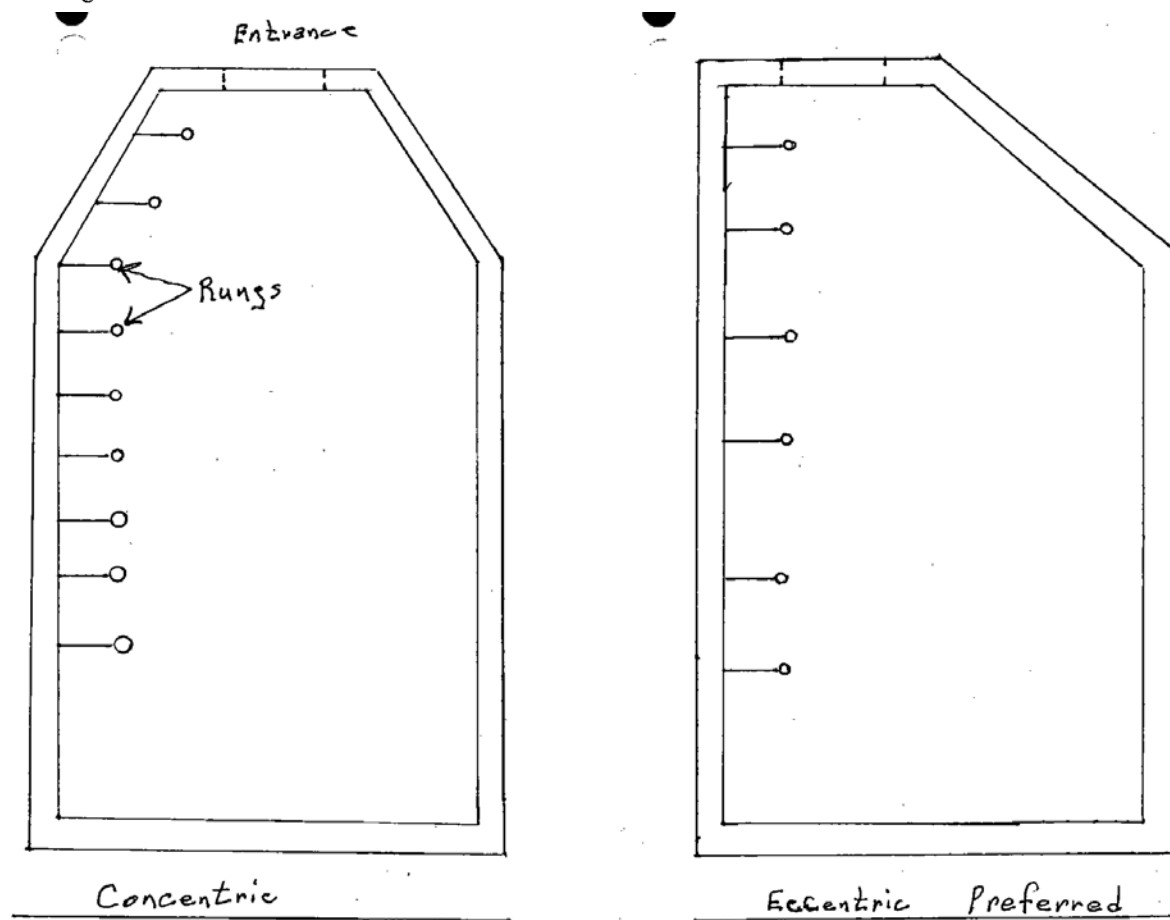

MANHOLES

Plumbing Fixtures

Typical fixtures specification –

1. Kohler brand vitreous china fixtures are The University of Memphis campus standard, but corresponding fixtures manufactured by American Standard and Gerber are acceptable.
2. Wall hung commodes will be hung on carriers manufactured by Wade or Zurn, so that no strain is transmitted to the closet connection.
3. Commodes and urinals requiring flush valves will use Sloan, Zurn, or ToTo fitted with automatic flush mechanisms.
4. P-trap, metallic, chrome plated, slip joint, size 1-1/4" and 1-1/2", 17 gauge, is minimum allowable wall thickness. PVC slip-joint p-traps are permissible in some locations if approved by the Owner.
5. Each fixture will have separate shut offs installed so that routine maintenance may be performed without interfering with the operation of adjacent fixtures.
6. Supply Tubes - may be either:
 - A. Semi-rigid, chrome-plated copper, bent using a tool designed for the purpose and attached to the stop using a 3/8" nut and copper ferrule.
 - B. Stainless steel mesh covered tube as supplied by Fluidmaster using permanently attached nuts appropriate to the individual fixture.
7. Laundry-room type sinks shall be "Fiat" brand sinks, either single tub or double tub models.
8. Electric Water Coolers - must be "Sunroc" brand, Model #NWC A8-002 as approved by ADA. Hawes and Elkay are acceptable substitutes.
9. Shower Towers - approved brand is "Shower Tower" by Swan, in various models to fit requirements.
10. Floor Drains - see "Piping Standards, Note #11."
11. Sinks, Stainless Steel - acceptable brands shall be "Elkay" or "Just," dimensions as required by situations; minimum thickness shall be 20 gauge, with sound deadening insulation.

Faucets

- DELTA: **only, single lever as selected**

Pipes and Pipe Fittings

- Galvanized piping shall not be used and shall be abandoned and removed where possible. All new domestic water piping to be copper.
- Do not use solder containing lead.
- All new sewer pipe, interior rain leaders, etc., to be made of cast iron.
- All steam, condensate, high-pressure drip, chilled water supply and return lines to be in separate conduits. Steam and chilled water service lines to have the insulation end stopped.

- Utility conduit system equal to Perma Pipe “P-P casing” for steam (schedule 40 pipe) or Perma Pipe “Poly-Therm” for condensate, chilled water supply and return (schedule 80 pipe) if direct buried. Tunnel systems are preferred and indicated in Contract Documents if required.
- Gland seals *are not allowed* on any utility conduit system.
- Provide an entrance pit where steam, condensate, and chilled water lines enter the building.
- All transmission lines to enter entrance pits horizontally through the pit walls. Use sleeves and link seals at each opening.
- Use sleeves and link seals (rated per code) at vertical penetrations of HVAC piping.
- HVAC drains to be sized a minimum of 1-1/2 inch ID. Fittings shall be DWV fittings.
- 6” roof drains – 4 inch is not sufficient

Valves

- Use threaded, full port bronze body ball valves with a stainless steel ball in a nylon or Teflon seat. Use no other unless dictated by code requirements. Do NOT use soldered valves.
- Provide full port ball isolation valves for each restroom and stops for each fixture.
- Use sleeves and link seals, rated per code, at vertical penetrations of plumbing piping.
- Install sufficient ball valves on transmission lines to allow shutting off the various systems.
- Do not use “Butterfly” or disc valves for any reason, unless first approved by the University.
- Vent all steam pressure relief valves to the outside of the building safely.

Reduced Pressure Devices

- Install reduced pressure backflow preventers per code at a maximum 7' above finished floor.
- Other devices may be required for the protection of the potable water for the campus. These may be taken from the Watts and Wilkins catalogues.
- ALL devices are to be installed in accordance with manufacturer’s instructions, taking into consideration accessibility of device.

ELECTRICAL

General Design Requirements

- All electrical devices to be UL listed and display the proper labeling.
- Retrofit all existing electrical systems (lighting, outlets, etc.) to meet present codes in renovation projects.
- All new transformers, switches, or other electrical devices to be free of PCB or asbestos.
- Connect the building communication systems, computer systems, and energy management/building automation systems (EMS or BAS) to the University’s network systems. See *Standards for Building Telecommunication Facilities*

- New equipment rooms to have an appropriate number of duplex ground fault interrupter receptacles mounted no lower than 4' above the finished floor.
- Provide one (1) 120v, 20 amp circuit for every vending machines.
- Provide an appropriate number of communication outlets – both telephone and network.
- Circuits DO NOT share neutrals
- MC cable switch leg only
- DO NOT use BODINE ballasts
- DO NOT use aluminum wiring or bus bars, screw type connectors, MR-16 in new installation or renovation.
- Provide WT sheets for all proposed fixtures
- Use LED where possible
- Multiple switch in presentation areas
- KEYRITE high voltage cable no substitute
- CT meters
- 120 volt, 20 amp minimum circuits
- All buildings and auxiliary units to be sub-metered to university system
- Nameplates shall be black laminated rigid phenolic with white core. Emergency nameplates shall be red laminated phenolic with white cores. Nameplate minimum size shall be 1 inch high by 3 inches long with 3/16 inch high engraved white letters. Supply blank nameplates for spare units and spaces.
- No junction boxes more than 24" above suspended ceiling grid.
- No conduit installed on top of bar joist. No conduit installed between roof deck and top of bar joist.
- All home run conduits shall be installed to a junction box in an accessible location above the ceiling before continuing to the first device, fixture, or equipment.
- Attachment of wires to devices shall be by screw pressure under the head of binding screws. **Arrangements depending on spring pressure or tension are not acceptable.** All binding screws shall be brass or bronze.
- 120 volt 20 amp duplex receptacles with two (2) USB charging outlets shall be installed in all classrooms, study areas, and dormitory rooms.
- Steel compression type conduit fittings only. (Set screw conduit fittings are not approved).
- Ground conductor to be installed with each circuit. Conduit shall not be used as ground path.
- Ground each outlet/device with approved bonding jumper from outlet/device to outlet/device box.

- Coordination of Protection and Arc Flash Survey shall be performed on new buildings, complete building renovations and new switchboard or panelboard installations. Arc flash hazard warning labels shall be installed on electrical equipment such as switchboards, panelboards, meter socket enclosures, motor control centers, etc. Arc flash warning signs/labels shall display the following information: Warning Arc Flash Hazard, Arc Flash Risk Category, Arc Flash Protection Boundary, Arc Flash Incident energy, Warning of Shock Hazard, Limited Approach Boundary, Restricted Approach Boundary, Prohibited Approach Boundary, and System Voltage.
- Main Switchgear/Main Switchboard shall have main circuit breaker.
- Main Switchgear/main switchboards shall have Power Standards Lab PQube power quality & energy analyzer metering equipment or equal.
- Motor Control Center (MCC) main bus shall be fully rated and arranged for future extensions.
- Switchgear, switchboards, distribution panels, etc. shall include all mounting hardware for all circuit breaker frame sizes for future extensions. Main horizontal bus bars shall be [standard taper per UL] fully rated and arranged for future extensions. All unused spaces shall be fully bused to accept future circuit breakers.
- 90 degree rigid metal conduit shall be installed on all turn ups on underground conduit installations.

Basic Electrical Materials And Methods

Circuit breakers - Must be designed and manufactured specifically for existing panelboards.

Conduit - Electrical metallic tubing, zinc coated, UL listed.

Conduit - Thin wall conduit, UL approved galvanized and zinc metallized electrical metallic tubing, Electrunted by LTV Steel Tubular Products Company. Utilize hex nut, expansion-gland type, and zinc plated Couplings and connectors. Crimp, string, or set screw type fittings are not to be used.

Device plate covers - Brushed 302 stainless steel, square chamfered edge, smooth face.

Device plate covers - Walker #829CK-1, #828R duplex fliplids, and #829S telephone slide coverplate, brass finish.

Device plates - Brushed 302 stainless steel, square chamfered edge, smooth face. Equal to Leviton 84000 series.

Device plates - Walker #817C one-gang, and #827C two-gang brass carpet flanges.

Dimmer switch - Leviton "Decora series" #82000-I, single pole slide, 2000W with 302 stainless steel Decora plate.

Disconnect switch - Square D, model #DU221RB, NEMA type 3R, 30 amps, not fusible, surface mounted.

Disconnect switch - Square D, model #DU322RB, NEMA type 3R, 60 amps, not fusible, surface mounted, exterior rated, 2 wire.

Disconnect switch - Square D, model #QO260NATS, NEMA type 1, 60 amps, not fusible, surface mounted, .

Disconnect switch - Square D, model QO200TR, NEMA type 3R, 60 amps, not fusible, surface mounted, exterior rated.

Drop Cords - Industrial duty, retracting overhead cord reel, Woodhead 9242, 10 gauge, 20 feet, 3 conductors with ground, terminate cord with NEMA L14-20 receptacle (3 pole/4 wire).

Duplex convenience receptacles - Leviton, ivory color, UL listed, 20A, 120V, commercial specification grade.

Load center - Square D, model #QO420L125 with surface cover QOC420LS, surface mounted.

Occupancy sensor system - Power Packs - Watt Stopper #A120-E or Watt Stopper #W1000A, ultrasonic, 24V DC.

Panel box - Square D or equal, NQOD20I100CU interior, NQB523 box and NQC23S cover, 100 amps MLO 20 space.

Panel box - Square D, NQOD430L100CU main lug interior, #NQC26F cover, 100 amps 30 spaces.

Projector screen momentary contact switch - Leviton #1257I, ivory color, single pole, double throw, center off, UL listed 20A, 120V, commercial specification grade.

Single convenience receptacles - Leviton, ivory color, UL listed, type as required for equipment, 250V, commercial specification grade.

Supporting devices - B-Line Systems channel type B22, 1-5/8" x 1-5/8", 12 gauge steel, finish hot dip galvanized after fabrication ASTM A 123. Provide all necessary hardware for mounting weatherproof enclosure to channels. Drill hole pattern to match electrical enclosure. Paint to match ?.

Surface mounted raceway - Wiremold Series 2000 metal raceway, 1 outlet, twelve receptacles, at 12" on center.

Surface mounted raceway - Wiremold Series 400 non-metallic raceway with base, cover, and device box. Mount base secure to partition with screws spaced 1'-6" apart. Ivory color.

Surface mounted raceway - Wiremold Series G-4000 two piece metal raceway with base, cover, and divider. All fittings and components should be designed for G-4000 raceway. Mount base secure to partition with screws spaced 1'-6" apart. Gray color.

Surface mounted raceways - Wiremold Series 500 metal raceway.

Surface mounted raceways - Wiremold Series 800 non-metallic raceway with base, cover, internal elbow, entrance end fitting, flat elbow, and extension box. Mount base secure to partition with screws spaced 1'-6" apart.

Switch - Leviton, ivory color, UL listed 20A, 120V, commercial specification grade.

Weatherproof enclosure - Hoffman A-30R3016HCR, NEMA 3R enclosure, 14 gauge G-90 grade galvanized steel, drip shield top, continuous hinge with stainless steel pin, hasp and staple for padlocking, dark gray enamel inside and out 30" x 30" x 16" deep. Back panel for above enclosure - Hoffman A-30P30.

Wire - Insulated copper, sized per code. Type THHN.

Wire - Insulated copper, sized per code. Type THHN/THWN. Conductors No. 10 AWG and smaller shall be solid and all other stranded unless otherwise noted. Minimum size conductor No. 12 AWG.

Connect new devices and lighting to existing circuits. Install components in strict accordance with manufacturer's installation instructions and approved submittals.

Light fixture Mark _____ - Wall mounted fluorescent, 120V, Brownlee #Carleton 1200-2x13-SWH, white finish 2 - 13W PL lamps.

Light fixture Mark _____ - Incandescent downlight, 120V Progress P7-TG housing with P6666 black step baffle, 75R30/FL/65WM G.E. lamp.

Light fixture Mark _____ - Incandescent downlight, 120V, Progress P6714-21 with mounting frame, 6-1/2" aperture, 120V, medium base, 6-7/8" ceiling opening. Progress P11-TG, reflector trim, specular clear, A-lamp cone, 100 Watt A19 IF, 130V lamp, recessed depth 10-1/4", outside diameter 7-3/4".

Light fixture Mark _____ - Wall mounted incandescent, 120V, Ron Rezek model #420 Arno, 100W A19 lamp, custom color - black.

Light fixture Mark _____ - Wall mounted incandescent, 120V, Progress P3030 or equal, 2 - 100W lamps, with chrome base, white and clear ribbed glass.

Light fixture Mark _____ - Wall mounted incandescent, 120V, Lightolier Lumiframe II #10477, 2 F40CW/WM lamps, with wraparound die formed steel finished in matte white, energy saving rapid start ballast. Provide uplight and downlight, 48" in length.

Light fixture Mark _____ - Hubbell NRG-417S1, 70W, 120 volt, HPS, ceiling mounted.

Light fixture Mark _____ - Downlight - Lithonia incandescent light fixture, U.L., 6" Universal Housing #LU6, with trim 6B3. Lamp - 90W A-19I.F., inside frosted, 130V.

Light fixture Mark _____ - Emergency lighting - Lithonia Emergency System #ELU2(P) 6volt, self contained. ??? (daycare center).

Light fixture Mark _____ - battery powered emergency light, Exide M200-2RH66, LED AC indicator, 120/277V output 6 volts DC 10AH battery, maintenance free operation.

Light fixture Mark _____ - Emergency lighting - Exide M200 2 H76T, 6volt, self contained.

- .. Existing light fixtures - Relocate, clean and reuse existing troffer mounted 2' x 4' fluorescent lights where indicated. Install new lamps ~~32 watt T8~~ and replace any broken lens as necessary. Relocate and center lamp holders for optimum light output on 2-lamp fixtures.

Light fixture Mark _____ - Type to match existing, 75A 130V incandescent lamps.

Connect new devices and lighting to existing circuits. Install components in strict accordance with manufacturer's installation instructions, NEC, and approved submittals.

Special Systems

1. Connect wiring to electric exit devices, power transfers, power boosters, timer and transfer switches. Route wiring concealed in storefront to area above concealed ceiling and connect to vendor provided activation device. Clearly mark/designate wiring and provide a wiring schematic. Install, secure, and terminate wiring in strict accordance with manufacturer's written recommendations and the requirements of the National Electric Code (NFPA 70.) The installation is intended to be fully complete and functional without any assistance from the University. Connect electrical wiring for power supply to building electrical system per code.

Communications

- .. projection screen provided by University, installed by General Contractor.

Controls

GFI convenience receptacle - Leviton 6399-1 NEMA-5-20R, ivory color, grounded, UL listed, 20A, 125V., commercial specification grade.

Duplex convenience receptacles - Leviton, ivory color, UL listed, 20A, 120V, commercial specification grade.

Duplex convenience receptacles - Hubbell, ivory color, UL listed, 20A, 120V, commercial specification grade with child resistant covers.

Switch - AC Quiet, Leviton 53521-I, ivory color, UL listed 20A, 120-277V AC, single pole, toggle, commercial grade.

Switch - Leviton, ivory color, UL listed 20A, 120V, commercial specification grade. Connect new devices and lighting to existing circuits. Install components in strict accordance with manufacturer's installation instructions.

Dimmer switch - Lutron Nova T, thin profile, single pole, slide to off dimmer, NT-600 600W or NT-1000 1000W as indicated, 120V AC, gray color, snap on multi-gang engraved gray faceplate where indicated.

Adjustable floorbox - Walker #880CM1, one-gang, and #880CM2, two-gang cast-iron floorbox.

Connect existing devices and lighting to existing circuits.

High Voltage Distribution

1. Above 600-Volt - Keyrite cable only

Service And Distribution

1. 600-Volt and Below - Square D and General Electric.

Raceways, Conduits, and Trenches

- Provide adequate conduit for telephone connections, cable, or future non-determined use.
- Relocate all existing exposed conduit to concealed spaces where possible. Run all new conduit in concealed spaces.
- Use no tie wires to support conduit. Caddy clips, if used, must be properly installed per manufacturer's requests.

Circuit Breakers

- SQUARE D -

Electric Conduit Fittings

- CARLON -

Electric Panels

- Size all branch circuit panel boards for a minimum of 25% spare capacity.
- SQUARE D – typical specification
- Switchboards and panelboards shall have hinged trim cover (door in door).

Electric Wires and Cables

- No aluminum wiring, conductors, or components to remain operational or be used in any renovation or new construction.
- Wires 8 AWG and smaller should be of proper color from the manufacturer (permanent and continuous color...no tape allowed to change/identify the color).

Elevators

- Elevator system - As approved. Generic elevator spec. Elevator should comply with our new specifications "non-proprietary equipment".
- Elevator controllers shall not require special service tool, troubleshooting or diagnostic equipment.
- Finishes - Stainless doors and frames, and radial tile or carpet floor. Walk off MANNINGTON Rough-in Walk Off carpet flooring. Brushed metal walls.
- Elevator fire department key box - As approved.
- HVAC for elevator equipment
- Elevator sump pumps
- Elevator Safety Equipment
- No penetrations into the elevator pit below grade
- Use only FR 68 bio degradable hydraulic oil.
- Must use vandal proof push buttons in car operating panel and hall call stations.

- Must use LED lighting in cab/car, riding lanterns, and position indicators
- Elevator fire department key box - As approved. For interior elevator key lock boxes located next to the elevators, **below is an excerpt taken from the state code for reference:**

Emergency Keyed Lock Box for Elevators

- Chapter 0800-3-15, Fire Safety for Elevators, of the 2005 Tennessee Acts, describes the general standards for the emergency keyed lock box as follows:
 - ...all student dormitories and other university housing with functioning elevators operating under control of the Board of Regents, and each state-owned public building under Department of General Services control, including the state capitol and capitol annexes must ensure that an emergency keyed lock box is installed. The general standards are as follows:
 - Approved Vendors:
 - Quality Elevator Co. (800) 222-3688
 - Fixture Co. (973) 341-8000
 - Elevator Products (847) 419-1419
 - Order Number for the box for the state of Tennessee is: FKBT
 - Key: universal key for Tennessee, Gamewell key # 25460 (Christmas tree cut). Keys provided by the vendors only to firefighters and state elevator inspectors.
 - Lock: Hoyl Industries, spring-latch locking with an operable key
 - Box Dimensions: 9"h x 5-3/8" w x 1-3/8" d
 - Color: Red
 - Door Covers: brushed or mirrored finish, bronze or stainless steel
 - Letters: 3/8" high in black with the first line FIRE DEPARTMENT, the second line ELEVATOR AUTHORITY, and the third line USE ONLY
 - The emergency keyed lock box shall be permanently mounted seventy-two inches from the floor to the center of the box at each bank of elevators at the main egress of the building, shall be operable by a universal key no matter where such box is located within the state of Tennessee, and shall contain only fire service keys and drop keys to the appropriate elevators.

Emergency Phones

- Emergency Phone (New Facility Interiors / Lobby) – Locations and type of emergency phone in lobbies of new facilities to be specified by The University of Memphis designer.
- Emergency Phone and Exterior Security Camera (Site) – ALL NEW installations to be TALK-A-PHONE COMPANY, ETP-MT/R-OP4 free-standing, vandal-resistant emergency phone tower (<http://www.talkaphone.com/product/etp-mtr-op4>). The tower has an integrated extension arm for mounting a PTZ dome camera (provided by the University), a flashing LED blue light and a

lighted faceplate. The tower contains an ADA-compliant communication device manufactured by TALK-A-PHONE. The LED blue light shall be continuously lit and flash for the duration of a call when the emergency button is pressed. The communication device shall be able to activate optional peripheral devices / activating a preset on a PTZ dome camera.

Exterior Lighting

- Lighting is the first line of defense in campus security and safety and provides needed visibility for vehicles and pedestrians to safely travel around campus. Lighting categories include (a) streets, (b) parking lots, (c) walkways, (d) athletic, and (e) common areas / open spaces around buildings. The goal is to preserve campus ambiance while ensuring well-lit areas of travel. This requires continuity of fixture types and luminaries.
- Lights frame open spaces and reinforce the overall structure of campus streets, walkways, quadrangles and open spaces. Space lights far enough apart to avoid daytime visual clutter and over lit areas at night. Design campus light levels to conform to IESNA standards (<http://www.ies.org>). Exterior lighting to be energy efficient and compatible with that of the existing area.

Exterior Building Lighting

- Spotlights and Wallpacks - [LITHONIA LIGHTING “D-Series”](#) LED lighting or approved equal:

Exterior Light Levels

- All exterior lighting to be metal halide or fluorescent meeting the following average foot-candle levels for the designated area: Walkways 3 fc; Building Entrances 10 fc; Open Lawns 3 fc; Large Open Areas 0.5 fc. See specifications, site plan, or Facility Plan.

Street and Parking Lot Lighting

- All exterior lighting to be LED meeting the following average foot-candle levels for the designated area: Parking 6 fc. and Parking Garages 12 fc. See specifications, site plan, or Facility Plan.

Post-top style street and parking lot light fixture shall be of the following or approved equal:

- [PHILLIPS LIGHTING](#) – “AeroScape” LED Lighting
- [BEACON PRODUCTS](#) – “VIPER” LED Lighting
- [LITHONIA LIGHTING](#) – “D-Series” LED Lighting
- Fixtures shall use either a partial cut-off shield or LED modules directing the light downward to reduce nighttime light pollution. Fixtures shall be anodized aluminum, Dark Bronze color.
- Poles shall be round, 30 foot anodized aluminum, and dark bronze color. Mount poles on a round concrete base at a 30” height.

Post Top Fixture

- Pedestrian light fixture for use along campus walks and certain campus streets shall be one of the following or approved equal:
- PHILLIPS LIGHTING – “AeroScape” LED Lighting
- BEACON PRODUCTS – “VIPER” LED Lighting
- LITHONIA LIGHTING – “D-Series” LED Lighting
- Fixtures and Pole shall be anodized aluminum, Dark Bronze color
- Fixtures shall use a partial cut-off shield OR LED modules directing light downward to reduce nighttime light pollution.
- Poles shall be 12’ high, 3” minimum round anodized aluminum, dark bronze, without inlet hole and mounted on a round concrete base at an 18” height.

Generators

- Emergency generator to provide power for new emergency systems and emergency lighting.
- ONAN Series of generators - <http://www.memphis.edu/cpd/pdfs/generators.pdf>
- Dark bronze color, screened with brick or metal screening.
- Must be sound attenuated. Level 2 sound attenuation. 73.5db.
- Must have 24 hour fuel capacity at full load.
- Must have remote annunciator panel.

High Voltage Switches

- G&W Electric Co. Series of switches

Interior Lighting

- Interior lighting to be energy efficient LED except in designated areas.
- Exit light – EXITRONIX 400U; Series WB-BL. Single or double faced diffused LED exit; die cast aluminum housing, supplied with completely universal design with 2 face plates, a back plate and mounting canopy. Optional features include self testing/diagnostic operation; flasher, buzzer, LED down light, damp rating, fire alarm interface, etc. Red or green LED’s, ¾” fully illuminated letters, constant uniform illumination, no visible LED’s, maintenance free, battery back-up; 25 year warranty, with 5 year pro-rated battery warranty with short circuit and voltage surge protection.
- Dispose of all fixtures removed. Verify all fixture locations before beginning installation. Connect new lighting to existing circuits. Install in strict accordance with manufacturers’ instructions, NEC, and approved submittals. Entire installation to be complete and functional without any assistance from the University.

- Lighting Controls – as approved by UM

Transformers

- 3 Phase General purpose dry type 600v and below -

ELECTRONIC

Fire Alarm Systems and Components

- Fire alarm reports to Miller and Police services
- All IT equipment in separate closet from ME or Electrical
- Door system – STANLEY BASIS
- All data wiring and terminations in project to be CA
- Clocks - SIMPLEX -
- Fire Alarm Equipment - SIMPLEX or Edwards
- SIMPLEX multi-application peripherals -
- Smoke Detectors - SIMPLEX
- Peripherals - SIMPLEX -
- Radios - MOTOROLA -
- Security Systems – as approved
- Intrusion Detection Remote Devices and Sensors -
- Occupancy sensor system – LEVITON “Decora” # OSSMT-MD/GD wall switch multi-technology occupancy sensor. NO SUBSTITUTION. Limited 5-Year warranty. For correct Model Number when ordering see data sheet

INTERIOR DESIGN

General Requirements

- All new ceilings to be acoustical lay-in panels, using standard stock ceiling tiles, unless another material is required by code and approved in writing by the University. Grid system to be University standard installed according to Guidelines for Seismic Restraint Direct Hung Suspended Ceiling Assemblies by Ceiling & Interior Systems Construction Association. Gypsum board ceilings not permitted for any application.
- Floors in private offices generally are to have carpet. Large areas of system furniture generally to have carpet tile modules. Assembly areas generally are carpeted. Hallways are generally vinyl composition tile. Other specific areas to match specific projects' Facility Plan.

- Card access readers must be included in the project according to University standards and details.
- Security vision lights to be considered in new door applications.
- Stacked seating – see attached “EDS Maestro 0608” sheet
- Interior paint to be semi-gloss enamels for halls, restrooms, classrooms, and trim and satin finish for offices.

Restrooms

- All toilet partitions to be floor mounted
- Toilet tissue dispensers to meet University standard specifications. Alwin unit 321.
- Turn towel roll dispensers to have a pull handle with automatic paper cutter.
- Floors and walls to be ceramic tile with minimum grout width. Substrate to be concrete, concrete backer board, or other approved waterproof material. Tile finish on walls to be matte glaze finish. Tile finish on floors to be unglazed.
- Countertops to be solid surface with integral bowls.
- Mirrors above lavatories to be full coverage.
- Private toilet rooms to have hat / coat hooks on the backs of doors provided and installed by the Contractor.

Toilet, Bath, and Laundry Accessories

- All items are to be sized, configured, and mounted to comply with all regulations and job requirements

Mirrors

- Mirror - BOBRICK B-290 1836, one-piece stainless steel frame, satin finish, float / plate glass mirror.
- Mirrors – Group - polished plate glass with pencil polished edges trimmed with multi piece metal channel frame system at top and bottom, adhered to substrate, custom size.
- Mirror – Single - BOBRICK B-165 series, one piece channel frame, and stock size.
- Mirror – Single - BOBRICK B-293 series, fixed tilt, stock size; use at accessible locations where BOBRICK B-165 series is unable to be mounted to meet accessibility requirements.
- Mirror - Polished plate glass with pencil polished edges mounted with nickel-plated brass J-clips #318 at top and bottom.
- Provide submittals and dimensions for approval, mount as directed.

Grab Bars

- Grab bars – BOBRICK B-5806 Series, 1 1/4" diameter stainless steel with concealed mounting snap flange, satin finish. Grab bar and concealed mounting plates to be type-304 stainless

steel with satin finish (or satin finish with peened gripping surface; add .99 suffix to model number). Grab bar wall thickness is 18-gauge and outside diameter is 1-1/4". Distance from inside of grab bar to finished wall shall be 1-1/2". Flanges shall be 1/8" thick stainless steel plate, 2" x 3-1/8" in diameter, and each shall have two screws holes. Flange covers shall be 22-gauge and snap over mounting flanges to conceal mounting screws. Grab bar shall have 90° return to flange. Ends of grab bar shall pass through flanges and be Heli arc welded to form one structural unit. Manufacturer service and parts manual to be provided to building owner/manager upon completion of project.

- Towel dispensers - (all dispensers must accommodate 8" or 9" 800' roll towels and have sub towel feature): [BOBRICK B-3960](#) series roll towel dispenser/waste receptacle, flush front unit (requires 9-5/8" depth mounting) where depth will not permit the above model the following model may be used if accessibility regulations permit: [BOBRICK B-3961](#) semi-recessed, similar to the above, (requires 4" depth mounting).
- Roll dispenser units only - no folded towel units. These semi recessed units must not interfere with any accessibility clearance. ADA mounting height to operate manual side turn mechanism is critical.
 - c. [BOBRICK B-39619 Classic](#), surface mounted, similar to the above (stainless steel skirt for surface mounting) where mounting requirements do not permit integrated dispensers / waste receptacles to be used and accessibility regulations permit, the following models may be used:
 - [BOBRICK B-3861](#) roll towel dispenser, flush front unit, (requires 9-5/8" depth mounting)
 - [BOBRICK B-38616 Classic](#) series roll towel dispenser, similar to above, semi-recessed for 3-1/2" walls
 - [BOBRICK B-2860 Classic](#) series roll towel dispenser, similar to above, surface mount (use coordinating waste receptacles from BOBRICK line, use fully recessed, semi-recessed, or surface mounted to coordinate to dispenser if possible and conditions / regulations permit, size capacity to job requirements, model numbers are to various to include herein).
 - Note: [BOBRICK](#) Contura series does not include a roll towel unit at the present time, determine if [BOBRICK](#) "Trimline" might be suitable instead. The University will accept the Trimline series if look of components throughout job can be coordinated and our standard towels and other supplies used. This will modify most model numbers herein.
- [GEORGIA PACIFIC 54338](#) - Wall mounted paper towel units (without waste units) for kitchenette/ break/ similar areas.
- Combination Roll towel / waste receptacle - [BOBRICK B-39617 Classic](#) series recessed convertible paper towel dispenser / waste receptacle.

Soap Dispensers

- Wall mounted soap dispensers - are black, SPARTAN Lite'n Foamy refillable dispensers provided by the University and installed by the Contractor. Vendor provides at zero cost to the University OR individual departments.
- Soap dispenser – At wall hung lavatories: [BOBRICK B-2111 Classic](#), corrosion resistant valve, satin finish stainless steel vertical soap dispenser. Mount per job and accessibility requirements and so drips are caught by lavatories and do not spill on floor. .
- Soap dispenser – At counter-set lavatories / vanities, moderate demand areas or counters with one, two, or three lavatories - [BOBRICK B-822 series](#), one per sink, top refilled, spout length to depend on lavatory type/size, capacity of individual units per demand. At high demand lavatories or counters with more than 3 sinks – [BOBRICK B-922 series](#) reservoir system, top refilled, spout length to depend on lavatory type/size, maximize capacity for group by interconnecting units full width with 3" black ABS piping, BOBRICK coupling T, and matching BOBRICK end caps. Lavatory layout and counter structure to coordinate with this product so units can interconnect. Units are plastic with double stick tape mounting.

Tissue Dispensers

- ALWIN Model 321

Sanitary Napkin Disposal

- Sanitary Napkin Disposal Unit - [BOBRICK B-354](#), Classic Series. Stainless steel with satin finish; partition mounted to serve 2 compartments. Use BOBRICK B-353 for recess wall mount application. For surface mounting where above units are not suitable to job requirements use [BOBRICK B-254](#). Do not include napkin/tampon vending units in contract. Provide submittals and dimensions for approval, mount as directed.

Signage

- Interior signage (including room numbering) to be according to University standard building signage requirements. APCO IM series
- Restroom Signage – Tennessee Code Annotated § 68-15-301 (2013). Required Posting: Each person, enterprise, agency or entity that maintains publicly-owned restroom facilities available to the general public shall post in a prominent place within each such restroom a sign, at least six inches (6") high and fourteen inches (14") wide, that reads as follows: "FOR GOOD HEALTH, PLEASE WASH YOUR HANDS" (2 lines). HISTORY: Acts 1994, ch. 920, § 1.

ARCHITECTURAL WOODWORK

- **Plastic-Laminate-Clad Architectural Cabinets**
 - **AWI Grades - NO SUBSTITUTIONS - Use AWI Premium grade at high finish areas only, use Custom grade as standard, or use Economy grade at low service and appearance areas only >>**
- **Laminate Clad**
- **End filler cabinet** - 45-pound industrial particleboard with interior blocking as required, covered with laminated clad, flush overlay design surface. AWI Custom ((or Premium)) grade. Laminate color, finish, and grades as selected from FORMICA, NEVAMAR, or WILSONART, to match existing building standards.
- **Corner brace** – STANLEY Hardware 997, 1" side length x ½" wide and/or 991, 2"L x 1"w, steel finish. Use particleboard screws to attach.
- **Cabinet pulls** - LAMP / SUGATSUNE, MRB-L 15/16" diameter knob, polished chrome.
- **Cabinet hinges** – BLUM Modul System, degree swing as selected.
- **Cabinet catches** – STANLEY magnetic SP41 (AL).
- **Drawer glides** – BLUM 430E, epoxy coated, full extension.
- **Custom veneer**
- **Cabinets** - Flush overlay design, AWI Premium Grade with exposed surfaces of highest-grade select mahogany veneer. Veneer on doors, appliance panels, and drawer fronts book matched. Finish surfaces with transparent stain and finish to match sample provided by the University. Semi-exposed surfaces to be liner grade high-pressure laminate; color as selected. Toe strip to be black high-pressure laminate.
- **Drawer slides** – BLUM 430E, epoxy coated, full extension.
- **Shelf brackets** - Chrome plated standard pins in 32mm-drilled standard.
- **Cabinet pulls** –as selected
- **Cabinet hinges** – BLUM Modul System, degree swing as selected.
- **Cabinet catches** – STANLEY magnetic SP41 (AL).
- **Birch**
- **Wall cabinets** - ¾" birch plywood with hardwood edge banding. Match existing building standards.
- **Residential grade**
- **Prefabricated cabinets** - MERRILLAT medium oak.

Room Numbering Procedure

- 1 In general, room numbers will be odd numbers on the front or exterior areas of a building, even numbers will be on the rear or interior areas of a building, starting counter-clockwise at the main or front entrance. Where special wings or areas are added to the front or back of a building, even numbers shall be placed on the right going from the main entrance or main portion of the building into the wing or additional area.

NOTE: The only change that might be made in this plan would be where special wings are added to the front or back of a building it might be wise to put the odd numbers on the right and the even numbers on the left to maintain continuity with the rest of the numbers in the building.
- 2 Any one corridor shall have even numbers on one side and odd numbers on the other side and shall not be mixed because an entrance is at the center of the corridor.
- 3 Room numbers on the lowest floor will be in the 100 series, on the first floor. The next full floor up will be in the 200 series, second floor, etc.
- 4 Room spaces will be numbered, not doors. When large spaces are involved, sufficient numbers shall be omitted to permit future assignment of space numbers should a large space be subsequently subdivided.
- 5 When an interior "storage" space serves two rooms, it shall be assigned the lowest adjacent room number with an A, B, C, etc. sub-designation.
- 6 Where several interior "storage" spaces open from one numbered room they shall be numbered the same as the main room and shall be given sub-designations A, B, C, etc., going clockwise from the main door of the main room.
- 7 All spaces shall be numbered including corridors, mechanical rooms, lavatories, etc.
- 8 Where a large number of spaces exist on one floor, a four-digit room number system will be assigned for the building in lieu of three-digit numbers.

Interior Tile

- Ceramic floor and base tile – AMERICAN OLEAN unglazed "Ceramic Classic" mosaic, 2" x 2" mosaic, flecked/granite look, with special shapes for outside corners, cove bases, and caps as required, price group 1 or 2, color(s) as selected. Thin-set epoxy adhesive installation over existing or repaired substrate, gray colored sanded grout, color as selected. 2"x2" with cove and 2-2x2 base; 2 modules high.
- Ceramic wall tile – AMERICAN OLEAN glazed wall tile, 4-¼" x 4-¼", bright glaze (or matte), with any matching trim shapes (special shapes as required), color(s) as selected. Thin-set adhesive installation, white colored grout. Allow for price group 1.

Resilient Base

- Resilient Base – FLEXCO Wallflowers 6" rubber set-on type, 1/8" gauge, 120' roll stock, and color as selected.
- Resilient Base – FLEXCO Wallflowers 4" rubber set-on type, 1/8" gauge, 120' roll stock, color as selected.
- Rubber Cove Base - JOHNSONITE 1/8" Rubber 4", Color: 32 Pebble.

Resilient Stair Treads and Risers

- Stair Risers, Stringers, and Treads – FLEXCO type 700 rubber tread with matching stringers and risers, color(s) as selected.
- Stair Treads - JOHNSONITE Rubber Stair Treads; Color: 32

Resilient Accessories

- Resilient rubber custom edge and termination – ROPPER #157 set-on type, rubber, 1-1/4" high, 12' section stock, color(s) as selected.
- Termination - Metal, type as required, color(s) as selected.

Chalkboards

- Chalkboard - CLARIDGE Series 800, Type A, Vitracite writing surface, color - #13 black, aluminum trim, map rail.

LCS board –

- CLARIDGE 24LCS 118 S; 1- 4' x 8' section with map rail. LCS white porcelain enamel writing surface, with anodized aluminum frame, 3/8" particleboard core, and .015 aluminum panel backing.

Plastic Toilet Compartments

- SANTANA SOLID PLASTIC PRODUCTS Hiny Hinders – Solid, one piece high-density polyethylene stiles, doors, and toilet partition panels, finish color as selected. Door contains an

integral hinge system, combination bumper /coat hook, door latch, and strike and keeper. Accessible door also includes door pull and wall stop. Provide continuous, full length plastic wall brackets, solid plastic shoes, leveling devices, head rail, security bolts, aluminum edge strips fastened to the bottom of all doors and panels, and related accessories per manufacturer's standards. Install according to manufacturer's instructions, approved shop drawings and submittals.

Exterior Design

- General Design Requirements
- Exterior building facades - shall incorporate basic elements of brick and limestone to match the existing campus environment unless specifically approved.
- Roofs are to be sloped.
- Entrance Prominence: main entrance to be clearly defined and identifiable.
- Provide space for newspaper and magazine stands near entrances with adequate public access.
- Plaza designs to conform to Campus Master Plan. Concrete reinforcing, patterns, widths and concrete mix to match campus standard details.
- Brick: blended, full range Charleston by general shale
- Curtain Walls: as approved
- Doors:
 - All new exterior entrance doors to be aluminum storefront insulated glass with airlock vestibule design and recessed floor mats.
- Precast: as approved

Signage:

- Each facility to have exterior building signage. Provide program and directional signage as required.
- University standard Logo / Symbol colors: FedEx/U of M Silver: #PMS 877; U of M Blue: #PMS 280; FedEx Purple: #PMS 2685. In cases where the metallic cannot be used for U of M, specify PMS 422.

Windows

- Windows shall be anodized frames with insulated UV protected low e glazing. Refer to specific projects' Facility Plan for detailed requirements of location. All exterior windows to be aluminum

frame and insulated glass with operable portions, aluminum finish as approved, generally natural.

- ADDITIONAL GUIDLELINES:
 - University of Memphis
 - University of Memphis Facilities Master Plan Update
 - Campus Master Plan Design Guidelines
 - Memphis and Shelby County Unified Development Code
 - University District Overlay
 - University District Comprehensive Plan
 - University Neighborhood Master Plan
 - University District Community Transportation Plan
 - University telecommunications standards
 - University lab standards